

Department of Engineering  
Tim Bryan, P.E., PTOE, County Engineer

3137 South Liberty Street, Canton, MS 39046  
Office (601) 855-5582 FAX (601) 859-5857

**MEMORANDUM**

April 15, 2026

To: Casey Brannon, Supervisor, District I  
Trey Baxter, Supervisor, District II  
Gerald Steen, Supervisor, District III  
Karl Banks, Supervisor, District IV  
Paul Griffin, Supervisor, District V

From: Tim Bryan, P.E., PTOE  
County Engineer

Re: Telepak Networks/D.B.A. Cspire Utility Permit  
County Road Name, Nissan Parkway

The Engineering Department recommends approval for Cspire to directional bore as drawings reflect to provide fiber to 363 Madison County Parkway for the Madison County Board of Supervisors to provide service to the new fire station.

Revised: 2/14/2019



## PERMIT APPLICATION FOR THE CONSTRUCTION OR ADJUSTMENT OF A UTILITY WITHIN COUNTY ROAD RIGHT-OF-WAY

Utility Information: Utility Name: Telepak dba C Spire Fiber

Address: 1018 Highland Colony Pkwy Ste 400 City/State/Zip: Ridgeland, MS 39157

Contact Person: Jon Huddleston Contact's Phone: 769-798-7284, jhuddleston@cspire.com

Project Information: County Road Name: Nissan Parkway

*(If located within more than one road right-of-way, use Appendix 1 for additional descriptions)*

Beginning Location: 32.59822310, -90.10065745 Ending Location: 32.60463129, -90.100700318

Length of Project: 2266' Section: 28 Township: 9N Range: 2E

Description of Work: Directional bore as drawings reflect to provide fiber to 363 Madison County Pkwy  
for State Contract-MADISON COUNTY BOARD OF SUPERVISORS / Amazon Fire Station

Check Box if Appendix 1 is to be included as a part of this Application

Whereas the above stated Utility makes application to the **Madison County Board of Supervisors** for a Construction Permit. Attached hereto are drawings and plans for the construction of the above facilities located within Madison County owned public rights-of-way. Once stamped by the Madison County Engineering Department, these plans shall not be changed or altered without written approval of the County Engineer, or his representative. A copy of the approved permit and plans shall be on-site at all times during construction.

The Applicant Utility shall comply with all policies, procedures and construction practices as outlined in *A Policy for The Accommodation of Utility Facilities within the Right-of-Way of all Public County Roads* (hereinafter referred to as the "Policy"), as adopted on November 1, 2005, by the **Madison County Board of Supervisors**, and which is hereby made a part of this Application Agreement.

If facilities are to be located within the Rights-of-Way of the County-Federal or State Aid System, Applicant Utility also agrees to comply with applicable provisions of *S.O.P. No. SA II-2-8, Accommodation of Utilities on Rights-of-Way*, issued by the State Aid Engineer and dated July 1, 2005.

The Applicant Utility understands and agrees that, except as herein granted, no right, title, claim, or easement to said road right-of-way is granted by the issuance of this permit. If this Utility is listed in the general provisions of the Policy, it will be adjusted to comply with same without cost to the County, unless the variance from the Policy has been approved by the granting of the Permit pursuant to this Application.

The Applicant Utility further understands that the Utility's engineering, plant, or other personnel will be responsible for the staking and construction supervision of the work set out above and as shown on the attached plans. If work impacts traffic in any way, the appropriate traffic control shall be installed per the *Manual of Uniform Traffic Control Devices*, Latest Edition.

The Applicant Utility understands that the County Engineer, or his representative, may issue a Stop Work Order at any time if it is deemed that site conditions are not suitable for construction or if any of the requirements of this permit are not being met.

Many County Roads have variable Rights-of-Way and/or no Right-of-Way at all and are maintained under a Prescriptive Easement. It is the sole responsibility of the Applicant Utility to verify the existence and limits of public rights-of-way. If none exists, it is the

responsibility of the Applicant Utility to acquire an easement for their Facilities from the applicable property owner(s). Madison County in no way verifies the limits of Right-of-Way as shown on the permit application.

The Applicant Utility shall be responsible for all future maintenance and repair of the facilities installed under this permit. The Applicant Utility shall make future adjustments to, or relocate, the facilities located within road or highway right-of-way when required for road or highway widening or other road or highway construction at no cost to Madison County. The Applicant Utility shall relocate said utilities within sixty (60) days of notification by County by registered mail, return receipt requested, unless otherwise designated by the County Engineer. Further, any maintenance, repair, or construction shall be done in such a manner as to occasion no unreasonable interference with the normal flow and safety to traffic and at the expense of the utility company. When reasonable care has been taken to locate said utility facilities within the right-of-way, the Applicant Utility understands that any damages caused by routine maintenance and construction by County forces shall be borne by the Applicant Utility.

The Applicant Utility further agrees to indemnify and hold Madison County harmless for any and all claims, accidents, damages, liabilities and expenses occasioned wholly, or in part, by any act or omission of applicant, its agents or employees. In case County shall, without fault on its own part, be made a party to any litigation commenced by or against applicant, then applicant shall protect and hold County harmless, and shall pay all costs, expenses and reasonable attorney's fees incurred or paid by County in connection with said litigation.

All underground facilities shall be installed at a depth equal to or greater than 48" below the lowest adjacent grade.

All pipes carrying liquid shall be encased under County maintained roads.

WITNESS the signature of the Applicant this the 15th day of April, 2026.

By: Jon Huddleston  
(Applicant Signature)

Title: OSP Permit Specialist

**Note:** *Applicant must be an employee of the Utility named in this application. The Madison County Board of Supervisors will not recognize a Contractor, Subcontractor, Agent, or Consulting Engineer as the Applicant. Utility Company shall be fully responsible for all work performed under this application.*

I, or my authorized representative, have reviewed this application and determined that the drawing, sketches, and plans submitted by the Applicant meet the requirements of *A Policy for The Accommodation of Utility Facilities within the Right-of-Way of all Public County Roads.*

**APPROVED**  
By **Tim Bryan at 4:25 pm, Apr 15, 2026**

Tim Bryan, P.E.  
County Engineer

AGREED TO AND APPROVED BY:

\_\_\_\_\_  
Madison County Board President

Date: \_\_\_\_\_

ENTERED INTO THE MINUTES OF THE BOARD OF SUPERVISORS OF MADISON COUNTY, MISSISSIPPI ON THIS \_\_\_\_\_ DAY OF \_\_\_\_\_, 20\_\_\_\_\_.



PERMIT SCHEDULE	
CITY	CANTON
COUNTY	----
DOT	----
DOT DISTRICT	----
RAILROAD	----
PIPELINE	N/A
PRIVATE EASEMENT	N/A
NATIONAL FOREST	N/A
WETLAND	N/A

AS-BUILT SCHEDULE	
FIELD ENGINEER	
PROJECT MANAGER	
CONSTRUCTION	
SUB CONTRACTOR	
INSPECTOR	
START CONSTRUCTION	
END CONSTRUCTION	
INSTALL FIBER	
FINAL CLEANUP	

General Notes



VICINITY MAP

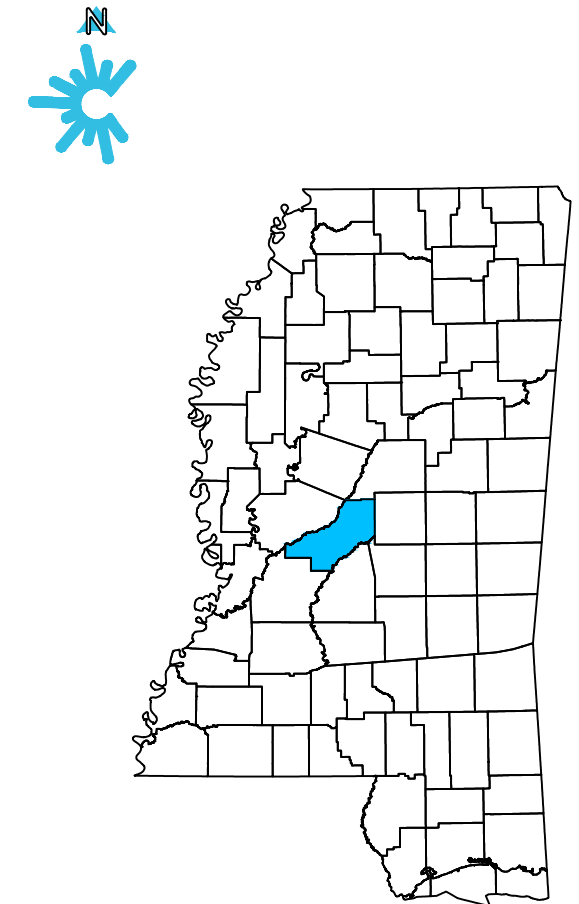

PREPARED BY

STATE CONTRACT-MADISON COUNTY BOARD OF SUPERVISORS CANTON  
 363 MADISON COUNTY PKWY, CANTON MS 39046  
 OSP Subproject 78070-001



4/14/26

**811** NOTIFY ALL UTILITIES 72 HOURS  
 PRIOR TO CONSTRUCTION ACTIVITY.  
 ONE CALL SYSTEM  
 1-800-227-6477



**CONSTRUCTION NOTES:**

1. ALL CONDUIT WILL BE 4" ID SCHEDULE 40 (ie. PVC OR BSP/GSP, MANUFACTURED SPLIT PVC OR SPLIT BSP/GSP), UNLESS SPECIFIED OTHERWISE.
2. CONTRACTOR IS RESPONSIBLE FOR LOCATING ALL UTILITIES 48 HOURS PRIOR TO CONSTRUCTION ACTIVITY.  
(811)  
MS 800-227-6477  
AL 800-292-8525  
TN 800-351-1111  
FL 800-432-4770
3. ALL UNDERGROUND OBSTRUCTIONS , WHEN LOCATED, WILL REQUIRE THE PLACEMENT OF A BURIED CABLE MARKER AND THE PLACEMENT OF 4" MANUFACTURED SPLIT PVC, BSP/GSP OVER OR UNDER EACH OBSTRUCTION.
4. SHORING MAY BE REQUIRED AND SHALL COMPLY TO O.S.H.A. STANDARDS.
5. ALL BURIED CONDUIT/CABLE WILL BE PLACED AT 36" MINIMUM COVER UNLESS CROSSING STATE AND OR COUNTY ROADS AND ALL CREEK BEDS UNLESS SPECIFIED OTHERWISE ON THE CONSTRUCTION DRAWINGS.  
48" MINIMUM DEPTH MAY BE REQUIRED.
6. MECHANICAL PROTECTION SHALL BE REQUIRED ANYTIME A 36" MINIMUM COVER IS UNOBTAINABLE UNLESS SPECIFIED OTHERWISE ON THE CONSTRUCTION DRAWINGS.
7. ALL 90 DEGREE BENDS IN CONDUIT CONSTRUCTION WILL BE A MINIMUM 38.2" RADIUS UNLESS SPECIFIED OTHERWISE. ALL SPLIT CONDUIT BENDS AND SOLID PVC BENDS SHALL REQUIRE CONCRETE ENCASEMENT, UNLESS SPECIFIED OTHERWISE.
8. OPERATIONS PERSONNEL TO BE CONTACTED BY THE CONTRACTOR 48 HOURS PRIOR TO CONSTRUCTION.
9. ALL STATIONING IS BASED ON AS-BUILT INFORMATION, THEREFORE SOME VARIANCE SHOULD BE ANTICIPATED. ADJUST AS NEEDED.
10. RAILROAD COMMUNICATION AND SIGNAL CABLES TO BE LOCATED PRIOR TO CONSTRUCTION ACTIVITY. RAILROAD TO BE GIVEN 48 HOURS NOTICE PRIOR TO CONSTRUCTION
11. ALL BURIED CONDUIT/CABLE WILL COMPLY WITH THE REQUIREMENTS OF THE JURISDICTION HAVING AUTHORITY.
12. CONSTRUCTION CONTRACTOR SHALL PLACE MARKER POLES AT REQUIRED LOCATIONS DURING THE CONSTRUCTION PHASE.

**GENERAL NOTES:**

1. ALL WORK TO BE DONE WITH EXTREME CAUTION, FIBER OPTIC CABLE CARRYING TRAFFIC AND LOSS OF SERVICE WILL RESULT IN LOSS OF REVENUE.
2. ALL WORK TO BE PERFORMED IN STRICT ACCORDANCE WITH THE APPLICABLE CODES OR REQUIREMENTS OF ANY REGULATING GOVERNMENTAL AGENCY, CSPIRE, OR THE RIGHT-OF-WAY GRANTOR.
4. UNDERGROUND UTILITIES HAVE BEEN PLOTTED FROM AVAILABLE RECORDS, FIELD OBSERVATIONS, OR SURVEY LOCATES BUT ARE NOT NECESSARILY EXACT. THEREFORE, UTILITY LOCATIONS WILL BE VERIFIED PRIOR TO CONSTRUCTION, SO THAT ADJUSTMENTS IN CABLE PLACEMENT CAN BE MADE PRIOR TO POTENTIAL CONFLICTS.
5. ALL KNOWN BURIED OBSTRUCTIONS ARE SHOWN ON THE CONSTRUCTION DRAWINGS. ANY AND ALL OTHERS ENCOUNTERED ARE ALSO THE RESPONSIBILITY OF THE CONTRACTOR TO LOCATE, PROTECT, AND REPAIR, IF DAMAGED.
6. ANY AND ALL IMPROVEMENTS, SUCH AS, ASPHALT OR CONCRETE PAVEMENT, CURBS, GUTTERS, WALKS, DRAINAGE DITCHES, EMBANKMENTS, SHRUBS, GRASS, SOD, ETC., IF DAMAGED, SHALL BE RESTORED TO ORIGINAL OR BETTER CONDITION.

**CLARIFICATION NOTES:**

NOTE: CALLOUTS WILL BE PLACED ON EACH DRAWING INDICATING FOLLOWING:  
 A. MATERIAL AMOUNT  
 B. DEPTH IF BURIED  
 C. SIZE OF FIBER  
 D. SIZE OF HDPE  
 E. SIZE OF STRAND  
 F. CABLE ID

**TRAFFIC CONTROL NOTES:**

ALL WORK SHALL COMPLY WITH THE UNIFORM TRAFFIC CONTROL MANUAL. (11TH EDITION OF MUTCD, JAN '24) OR NEWER VERSIONS OF THIS MANUAL.

**NOMENCLATURE**

**DEFINITION**

- |               |   |
|---------------|---|
| 1. BM2-8 :    | PLACEMENT OF EIGHT FOOT GROUND ROD OUTSIDE OF HAND HOLE SIX INCHES BELOW GROUND LEVEL WITH PLACEMENT OF GROUND WIRE WITH CONNECTOR.   |
| 2. BM53F :    | PLACEMENT OF PLASTIC MARKER POLE, MINIMUM OF 30" IN GROUND AS INDICATED BY DRAWINGS.  |
| 3. BM53F(A) : | PLACEMENT OF LOCATE MARKER POST AND PLACEMENT OF WIRE INSIDE OF POST FROM GROUND ROD AND SPLICE CLOSURE TO BE TERMINATED IN POST FOR LOCATION OF FACILITIES AS INDICATED ON DRAWINGS. |

**SYMBOL**

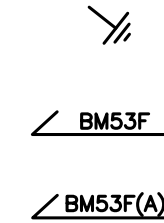

NOTIFY ALL UTILITIES 72 HOURS PRIOR TO CONSTRUCTION ACTIVITY. ONE CALL SYSTEM @ 1-800-227-6477

DISCLAIMER:  
EXCEPT AS MAY BE OTHERWISE PROVIDED BY CONTRACT, THESE DRAWINGS AND SPECIFICATIONS SHALL REMAIN THE PROPERTY OF TELEPAK NETWORKS INC. BEING ISSUED IN STRICT CONFIDENCE AND SHALL NOT BE REPRODUCED, COPIED, OR USED FOR ANY PURPOSE WITHOUT SPECIFIC WRITTEN PERMISSION.

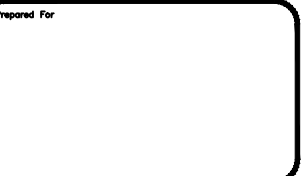

Date	4/14/2026	Map Number	T-1
Scale			
Sheet 2 of 17			

# SYMBOLS KEY



DIRECTIONAL BORE	
AERIAL CABLE	
PLOW OR BURIED CABLE	
DIRECTIONAL BORE 5" HDPE	
PVC OR SPLIT PVC CONDUIT	
ASTMA 139 GRADE B STEEL	
JACK AND BORE	
CORE BORE	
EXISTING CSPIRE CABLE	
PROPOSED HANDHOLE	
EXISTING HANDHOLE	
PROPOSED BORE PIT	
PROPOSED MANHOLE	
H-FRAME	
HANDHOLE (CABLE IN HDPE)	
HH (CABLE IN PVC CONDUIT)	
HANDHOLE (CABLE IN GSP CONDUIT)	
MANHOLE (CABLE IN HDPE)	
MANHOLE (CABLE IN PVC CONDUIT)	
MANHOLE (CABLE IN BSP/GSP CONDUIT)	
ROW MARKER (FOUND)	
ROW MARKER (NOT FOUND)	
ROW/PROPERTY PIN	
MILE MARKER	
STAKE	
MONUMENT	
LIGHTNING ARRESTOR	
AC/DC FILTER PROTECTION	
ALUMINUM HUB STYLE MARKER	
STEEL MARKER	
FLAT COMPOSOLITE MARKER	
TUBULAR MARKER	
GROUND WIRE	
BOND AND GROUND	

RAILROAD TRACKS	
CENTERLINE	
DOT CENTERLINE	
BUILDING	
FENCE	
GUARDRAIL	
WOOD LINE	
DITCH LINE	
TOP/TOE OF SLOPE (TOS)	
AERIAL UTILITY (ELECTRIC)	
BURIED GAS MAIN	
BURIED WATER MAIN	
BURIED POWER	
BURIED COMMUNICATIONS	
UNKNOWN/OTHER UTILITY	
BURIED TRAFFIC SIGNAL CABLE	
SEWER	
DOT FIBER OPTIC CABLE	
UTILITY/POWER POLE	
POLE WITH PEDESTAL	
STREET/SIGNAL LIGHT	
PARKING METER	
COMM MARKER	
COMM MANHOLE	
SIGN	
RAILROAD SIGNAL	
POST	
TREE	
CURB INLET	
SEWER MANHOLE	
WATER VALVE	
FIRE HYDRANT	
GAS VALVE	
GUY/ANCHOR	
PEDESTAL	
TRAFFIC SIGNAL	
TRANSFORMER	
HANDHOLE	
UTILITY MARKER	
MAILBOX	
SIGNAL ARM	
COLUMN	
BUSH	
DRAIN INLET	
DRAIN MANHOLE	
IRRIGATION VALVE	
WATER METER	
GAS METER	

ANCHOR ONLY (EXISTING)		ANCHOR AND GUY WHOLLY OWNED BY ANOTHER COMPANY	
GUY ONLY (EXISTING)		SIDEWALK ANCHOR & GUY	
PROPOSED ANCHOR & GUY		PROPOSED SIDEWALK ANC & GUY	
ACCOUNT CODE CHANGE (BURIED - AERIAL)			
OVERHEAD GUY (ARROW IN DIRECTION OF PULL)		92' 10M	OHG
PROPERTY LINE			
EDGE OF PAVEMENT		EOP	EOP
BACK OF CURB		BOC	BOC
WHITE LINE		W/L	W/L
RIGHT-OF-WAY LINE			
TAX DISTRICT BOUNDARY		T038-42	51762A
PROBE (DEPTH AS INDACATED)		42"	
PERMIT TRACKING FORM IDENTIFIER		P.T.F.	187

## POLE ATTACHMENT ABBREVIATIONS

PWR	POWER ATTACHMENT	PWR OHG	POWER OVERHEAD GUY
TRI	TRIPLEX	CATV OHG	CATV OVERHEAD GUY
COMM	COMMUNICATIONS ATTACHMENT	CAP BANK	CAPACITOR BANK
CATV	CATV ATTACHMENT	CLTCKT	FIRE ALARM CIRCUIT
SL	STREET LIGHT	PWR DIP	POWER DIP
TSIG	TRAFFIC SIGNAL	COMM DIP	COMMUNICATIONS DIP
MDW	MULTI DROP WIRE	CATV DIP	CATV DIP
COMM OHG	COMMUNICATIONS OVERHEAD GUY	TEOP	TRAFFIC LIGHT
FL	FLOOD LIGHT	TGUY	TRAFFIC GUY
WH	WEATHER HEAD	MS	MIDSPAN
TRAN	TRANSFORMER	OHG	OVERHEAD GUY
TELEPAK	TELEPAK ATTACHMENT	TOP	TOP OF POLE
SEC	SECONDARY POWER	NEU	NEUTRAL

CAUTION NOTES				
---------------	--	--	--	--

**General Notes**  
  
 NOTIFY ALL UTILITIES 72 HOURS PRIOR TO CONSTRUCTION ACTIVITY. ONE CALL SYSTEM @ 1-800-227-6477

No.	Revision/Issue	Date

DISCLAIMER: EXCEPT AS MAY BE OTHERWISE PROVIDED BY CONTRACT, THESE DRAWINGS AND SPECIFICATIONS SHALL REMAIN THE PROPERTY OF TELEPAK NETWORKS INC. BEING ISSUED IN STRICT CONFIDENCE AND SHALL NOT BE REPRODUCED, COPIED, OR USED FOR ANY PURPOSE WITHOUT SPECIFIC WRITTEN PERMISSION.

Prepared By

Prepared For

Project Details

Date	4/14/2026	Map Number	T-2
Scale			
Sheet 3 of 17			



## PLACEMENT-TYPICALS

**TYPICAL DETAIL "A"**  
PLACE CONDUIT CROSS SECTION

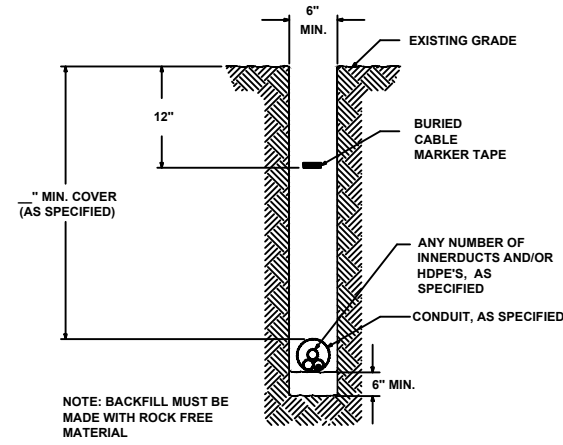

**TYPICAL DETAIL "B"**  
PLACE HDPE CROSS SECTION

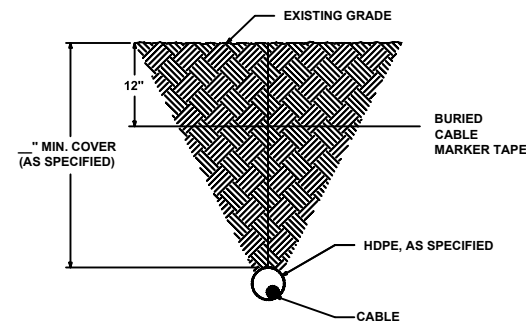

**TYPICAL DETAIL "C"**  
CONCRETE / PAVEMENT OPEN CUT CROSS SECTION

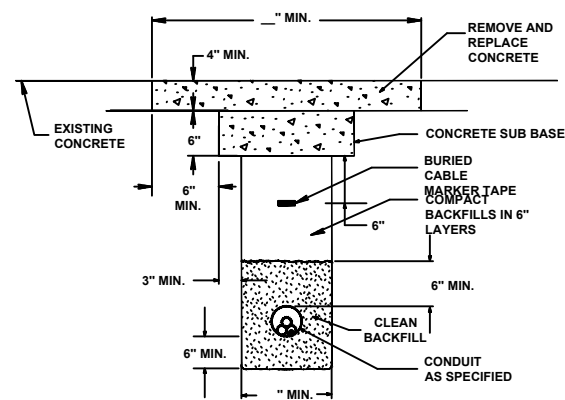

**TYPICAL DETAIL "D"**  
ASPHALT/PAVEMENT OPEN CUT CROSS SECTION

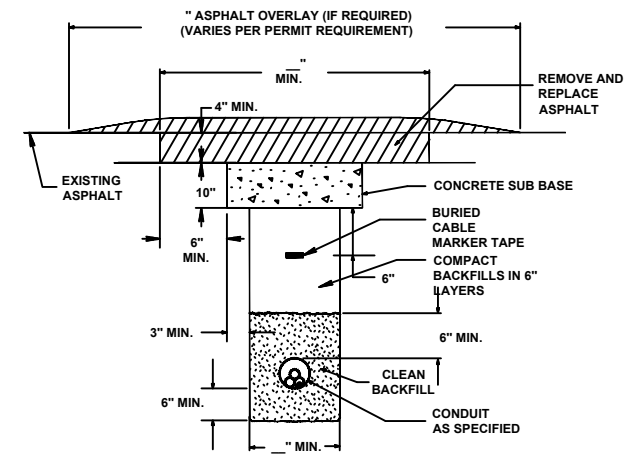

## OPEN CUT-TYPICALS

**TYPICAL DETAIL "E"**  
BORE CONCRETE SIDEWALK

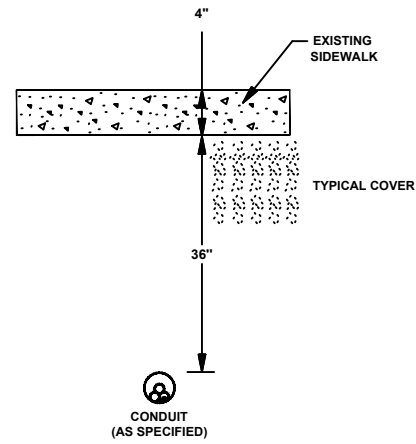

**TYPICAL DETAIL "F"**  
CORE BORE  
(CONCRETE / BRICK WALL)

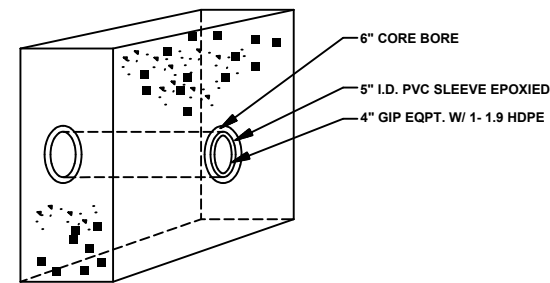

**TYPICAL DETAIL "G"**  
12"x12" CONCRETE ENCASEMENT

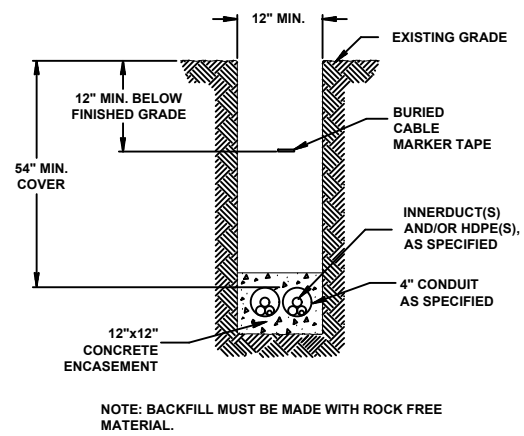

**TYPICAL DETAIL "H"**  
PLACE (2) 1.25" HDPE IN CONDUIT



**TYPICAL DETAIL "I"**  
PLACE CABLE IN HDPE

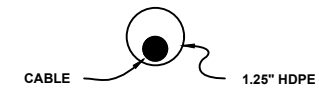

**TYPICAL DETAIL "J"**

MANHOLE & HANDHOLE SLACK COIL DETAIL

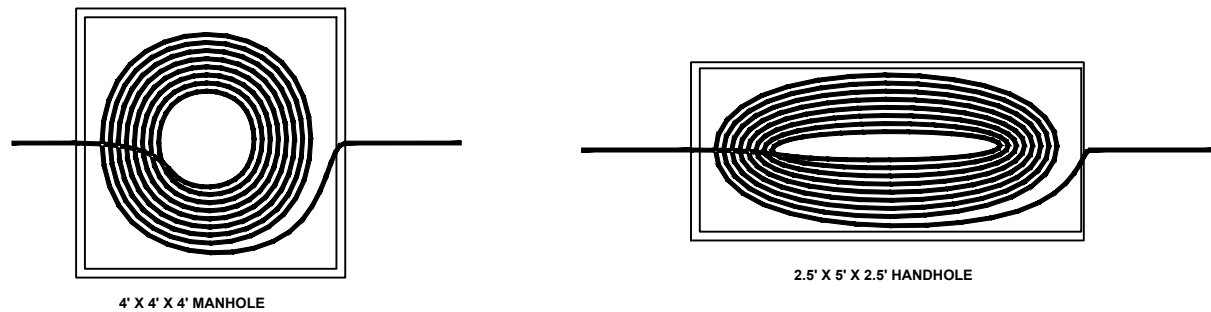

**TYPICAL DETAIL "K"**

HANDHOLE INSTALLATION IN CONCRETE / ASPHALT CROSS SECTION

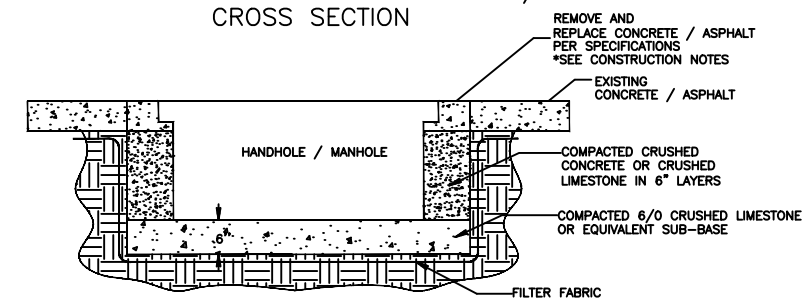

General Notes



NOTIFY ALL UTILITIES 72 HOURS PRIOR TO CONSTRUCTION ACTIVITY. ONE CALL SYSTEM @ 1-800-227-6477

No.	Revision/Issue	Date

DISCLAIMER:  
EXCEPT AS MAY BE OTHERWISE PROVIDED BY CONTRACT, THESE DRAWINGS AND SPECIFICATIONS SHALL REMAIN THE PROPERTY OF TELEPAK NETWORKS INC. BEING ISSUED IN STRICT CONFIDENCE AND SHALL NOT BE REPRODUCED, COPIED, OR USED FOR ANY PURPOSE WITHOUT SPECIFIC WRITTEN PERMISSION.

Prepared By



Prepared For

Project Details

Date 4/14/2026

Scale

Sheet 4 of 17

Map Number

T-3



# CAPITOL CONCRETE PRODUCTS, INC

FIBER OPTIC/LIGHTGUIDE  
SPLICE VAUEOP  
4'-0"X4'-0"X4'-0"

GRADE 60 REINFORCEMENT  
4500 PSI CONCRETE  
REINFORCEMENT FOR  
AASHTO M-20 LOADING

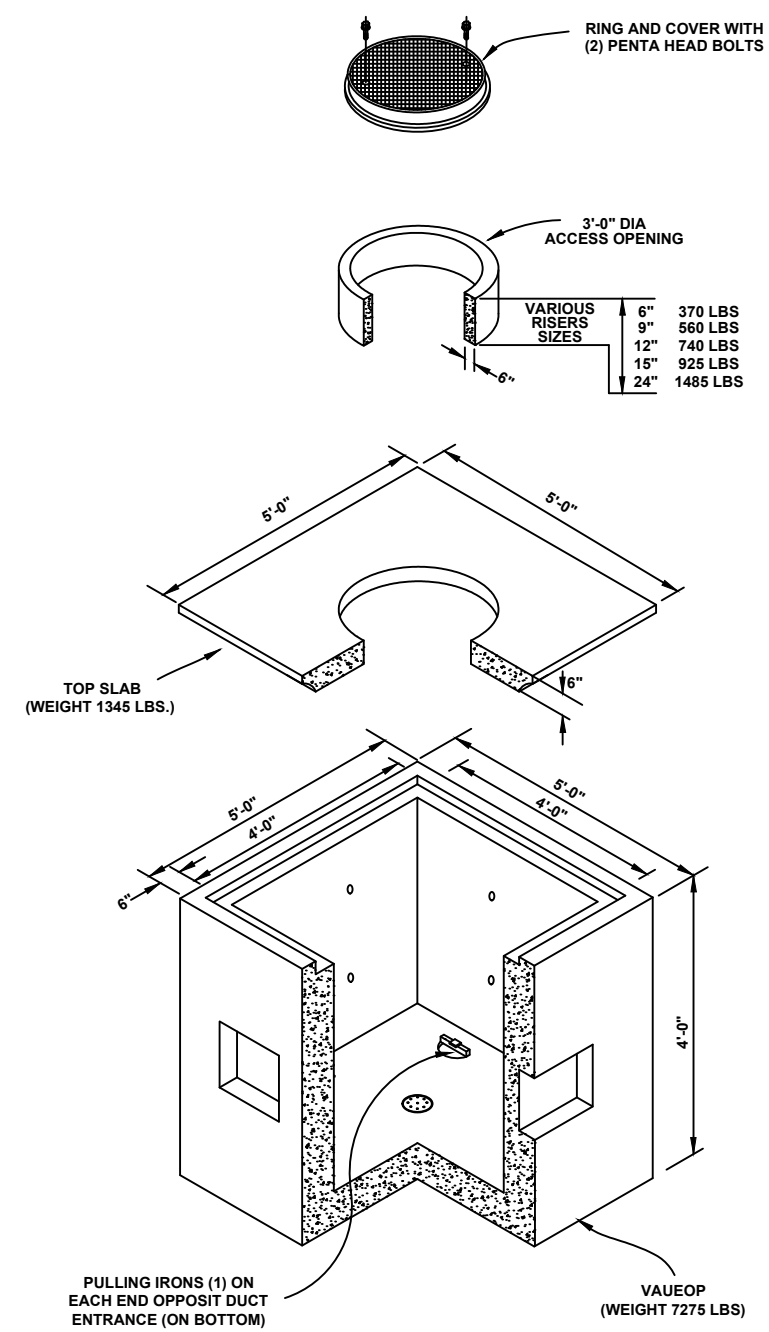

### General Notes



NOTIFY ALL UTILITIES 72 HOURS PRIOR TO CONSTRUCTION ACTIVITY. ONE CALL SYSTEM @ 1-800-227-6477

No.	Revision/Issue	Date

DISCLAIMER: EXCEPT AS MAY BE OTHERWISE PROVIDED BY CONTRACT, THESE DRAWINGS AND SPECIFICATIONS SHALL REMAIN THE PROPERTY OF TELEPAK NETWORKS INC. BEING ISSUED IN STRICT CONFIDENCE AND SHALL NOT BE REPRODUCED, COPIED, OR USED FOR ANY PURPOSE WITHOUT SPECIFIC WRITTEN PERMISSION.

Prepared By



Prepared For

Project Details

Date 4/14/2026

Map Number

Scale

T-4



# UH-5

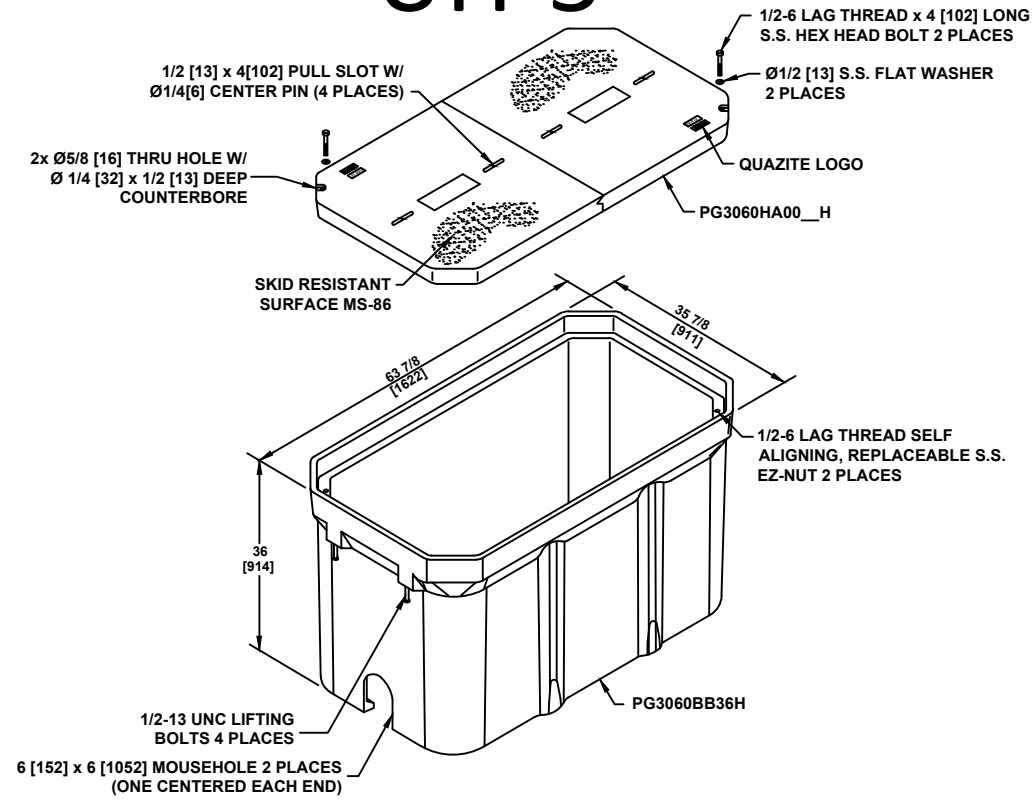

# UH-4

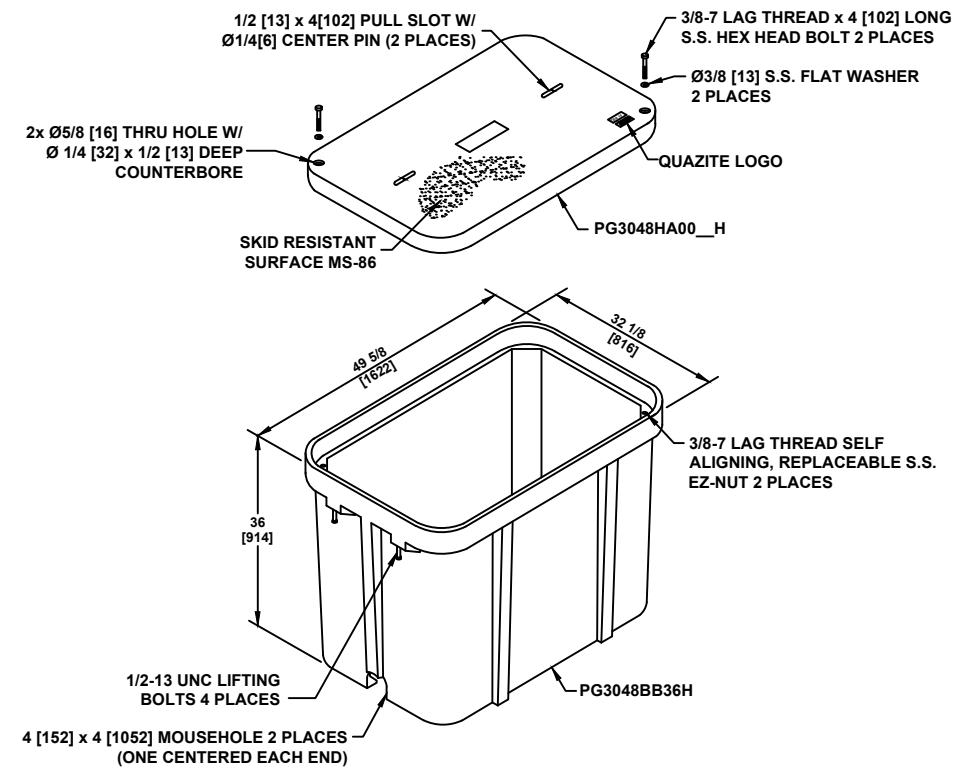

# UH-3

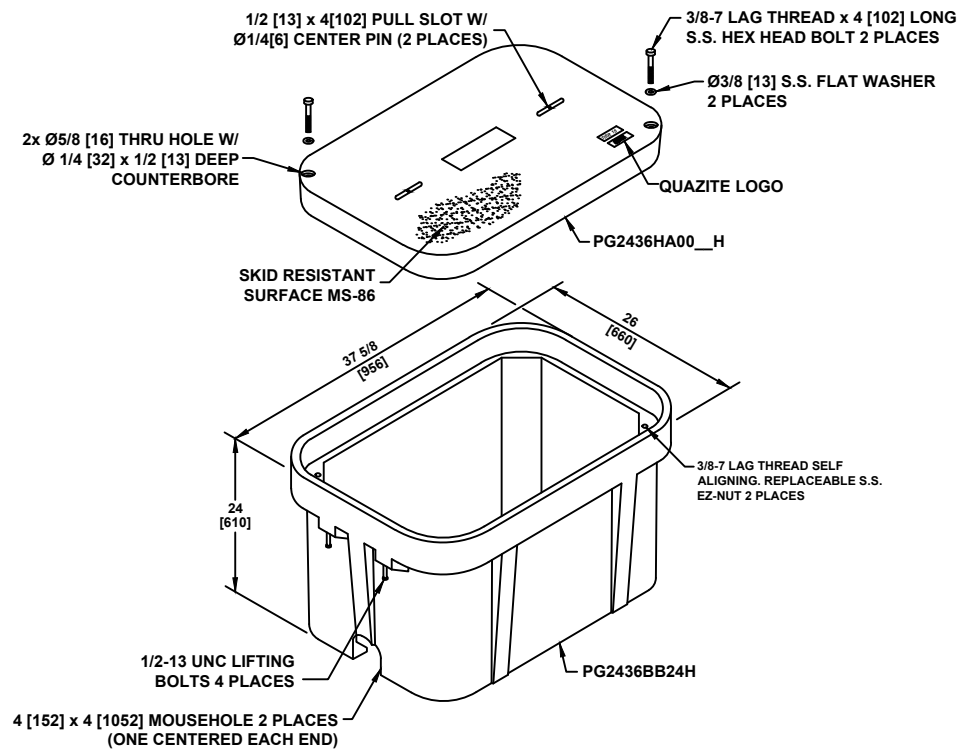

# UH-2.5

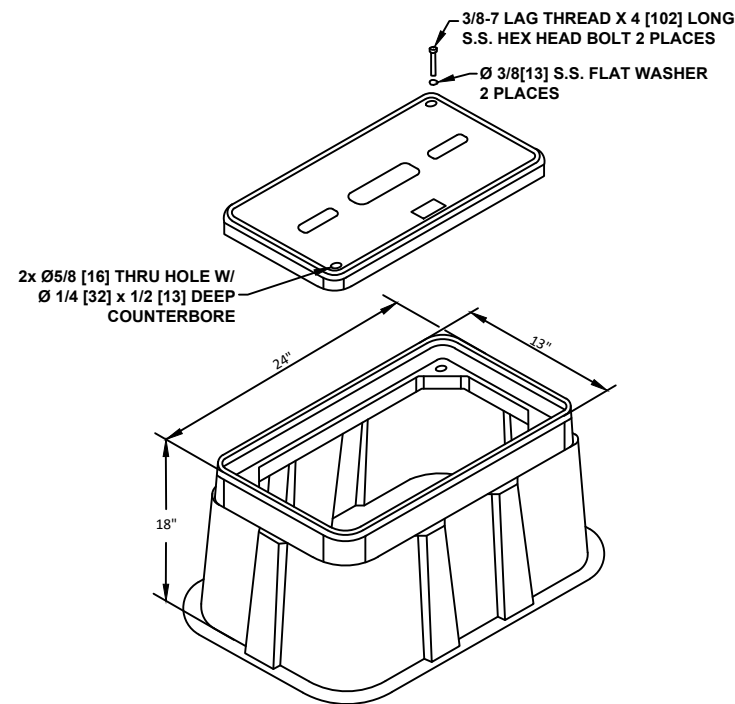

# UH-2

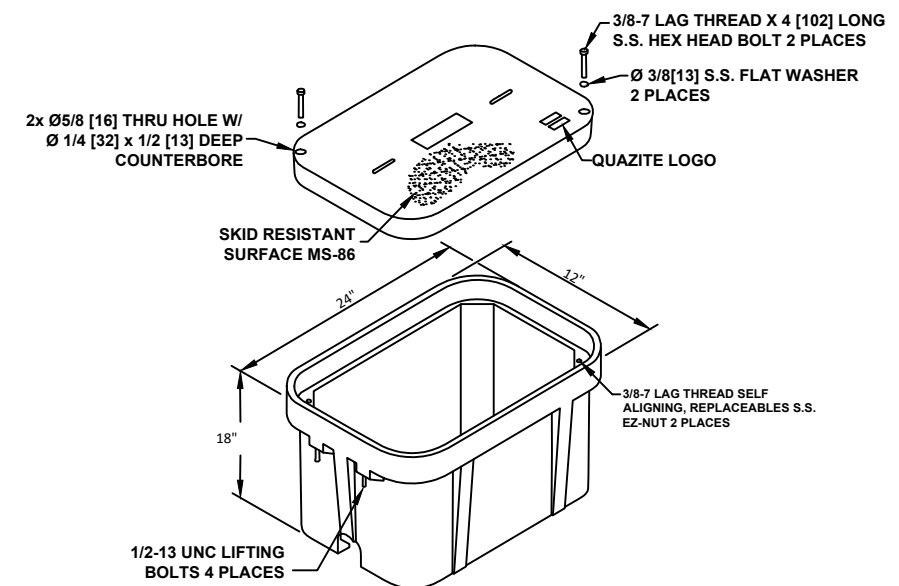

### General Notes



NOTIFY ALL UTILITIES 72 HOURS  
PRIOR  
TO CONSTRUCTION ACTIVITY.  
ONE CALL SYSTEM @  
1-800-227-6477

No.	Revision/Issue	Date

DISCLAIMER:  
EXCEPT AS MAY BE OTHERWISE PROVIDED BY  
CONTRACT, THESE DRAWINGS AND SPECIFICATIONS  
SHALL REMAIN THE PROPERTY OF TELEPAK  
NETWORKS INC. BEING ISSUED IN STRICT  
CONFIDENCE AND SHALL NOT BE REPRODUCED,  
COPIED, OR USED FOR ANY PURPOSE  
WITHOUT SPECIFIC WRITTEN PERMISSION.

Prepared By



Prepared For

Project Details

Date 4/14/2026

Map Number

Scale

T-5

Sheet 6 of 17



## TYPICAL HAND HOLE INSTALLATION

MARKER POST WITH LOCATE PIGTAIL CENTERED BEHIND HANDHOLE

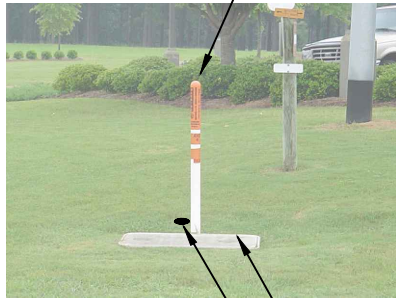

8" x 5/8" GROUND ROD 6" BELOW GROUND AND 6" TO THE LEFT OF MARKER POST OUTSIDE OF HANDHOLE

PIGTAIL INSTALLED IN H/H WITH LONG WIRES (CONNECTORIZED ENDS) FED UP INTO MARKER POST AND SHORT WIRE TO GROUND ROD

AT EVERY HANDHOLE LOCATION WITH A MARKER POST, 1.25" HDPE SHOULD EXTEND 48" INTO MARKER POST. HDPE SHOULD ALSO EXTEND 6" ABOVE GRAVEL AT THE BOTTOM OF THE HANDHOLE.

AT EVERY TEST STATION, BURY GROUND ROD 6" BELOW GROUND AND 6" TO THE LEFT OF MARKER POST

BLACK WIRE BONDED TO 8" GROUND ROD AT TEST STATIONS ONLY  
PLACE BLUE TAPE NEAR THE TOP OF HDPE TO INDICATE THE DUCT LEADING TO MARKER POST

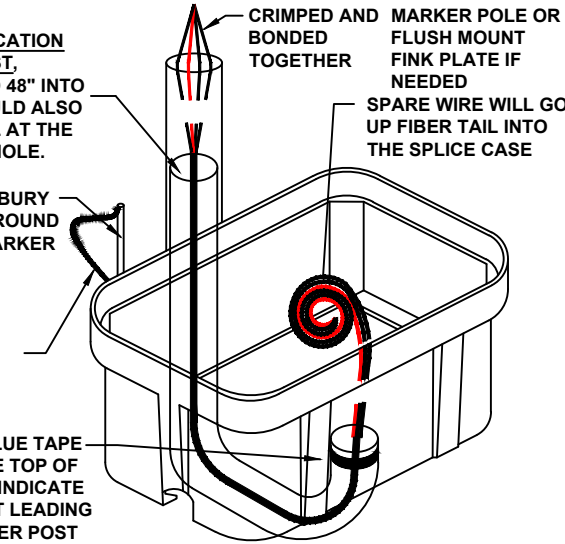

**NOTES:**

1. THIS ASSEMBLY IS RATED FOR A STATIC DESIGN LOAD OF 15,000 LBS. [66,720 N] OVER A 10 [254] X 10 [254] AREA AND MUST PASS A MIN. STATIC TEST LOAD OF 22,500 LBS. [100,085 N].
2. ALL ENCLOSURES, BOXES AND COVERS, ARE REQUIRED TO CONFORM TO ALL TEST PROVISIONS OF ANSI/SCTE 77 2007 "SPECIFICATION FOR UNDERGROUND ENCLOSURE INTEGRITY" AS MANUFACTURED BY QUAZITE OR EQUIVALENT WITH TELEPAK NETWORK'S ENGINEER'S SIGNED APPROVAL. THE COVERS MUST BE RATED FOR TIER 15 APPLICATIONS AND BOXES RATED FOR TIER 22 APPLICATIONS AND IN NO ASSEMBLY CAN THE COVER DESIGN LOAD EXCEED THE DESIGN LOAD OF THE BOX. ALL COMPONENTS IN AN ASSEMBLY (BOX & COVER) ARE MANUFACTURED USING MATCHED SURFACE TOOLING. ALL COVERS ARE REQUIRED TO HAVE A MINIMUM COEFFICIENT OF FRICTION OF 0.50 IN ACCORDANCE WITH ASTM C 1028 AND HAVE TIER 15 AND "TELEPAK NETWORKS 800-342-3716" EMBOSSED ON THE TOP SURFACE. ALL COVER BOLTS TO BE SELF-CLEANING AUGER BOLT ASSEMBLIES.

## TYPICAL BUDI BOX, SKIRT & ONT COMBO OUTDOOR INSTALLATION PROCEDURES AT BUILDING ENTRIES

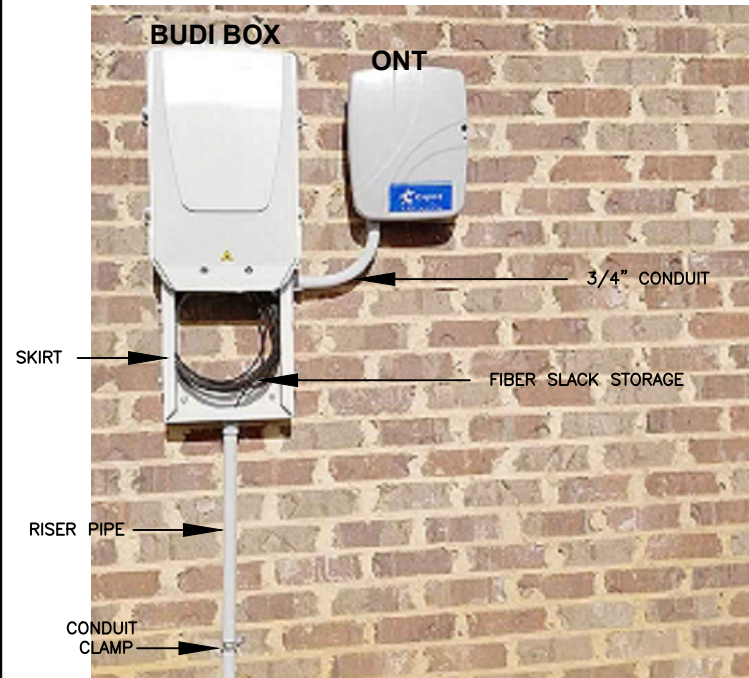

1. PLEASE MOUNT BUDI BOX 36" OFF THE GROUND UNLESS OTHERWISE STATED ON THE DRAWINGS.
2. BUDI BOX & ONT INSTALLATION LOCATION WILL BE SHOWN ON THE CONSTRUCTION DRAWINGS. PLEASE DO NOT USE PICTURES AS A HEIGHT INDICATOR FOR THE INSTALLATION.
3. MOUNT 3' RISER PIPE TO THE WALL USING SHOWN CONDUIT STRAPS.
4. JOIN RISER PIPE TO SKIRT AT SHOWN LOCATION & MOUNT BUDI BOX & SKIRT TO WALL.
5. USING A 3/4" SWEEPING 90, CONNECT SKIRT TO ONT AND MOUNT ONT TO WALL.
6. PLACE FIBER FROM DUCT INTO RISER PIPE AND INTO SKIRT LEAVING A 5' SLACK LOOP.

## BUDI BOX, SKIRT & ONT COMBO OUTDOOR INSTALLATION COMPLETED INSTALL



## TYPICAL UH-1 / UH-2 HAND HOLE INSTALLATION PROCEDURES AT BUILDING ENTRIES



UH-1 / UH-2 INSTALLATION LOCATION WILL BE MARKED BY A STAKE AND/OR PAINT. CSPiRE/OSP WILL INSTALL CONDUIT 8" UNDERGROUND TO DESIRABLE UH-1 LOCATION.

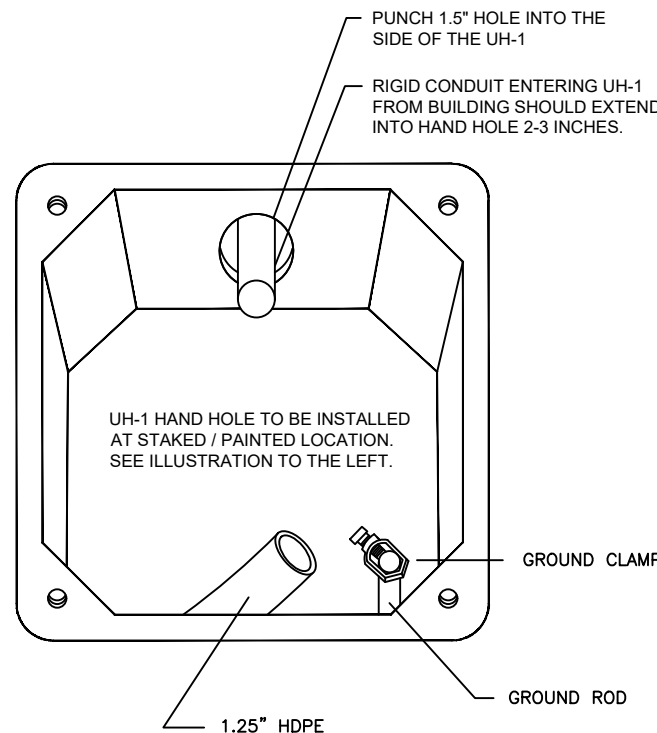

## TYPICAL ONT OUTDOOR INSTALLATION PROCEDURES AT BUILDING ENTRIES

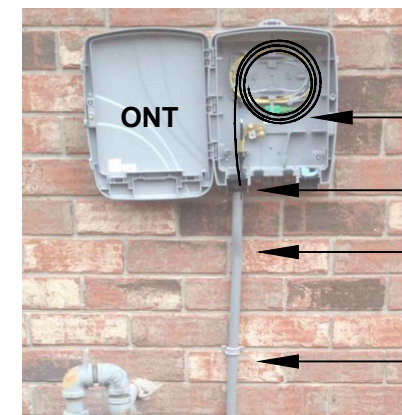

1. PLEASE MOUNT ONT 48" OFF THE GROUND UNLESS OTHERWISE STATED ON THE DRAWINGS.
2. ONT & FDP INSTALLATION LOCATION WILL BE SHOWN ON THE CONSTRUCTION DRAWINGS. PLEASE DO NOT USE PICTURES AS A HEIGHT INDICATOR FOR THE INSTALLATION. MOUNT ONT AS CLOSE TO THE POWER METER AS POSSIBLE
3. DUCT PLACED BY DIRECTIONAL BORING SHOULD MEET THE RISER PIPE UNDERGROUND NEAR THE BASE OF THE WALL. A 4" GAP BETWEEN THE DUCT AND THE RISER PIPE IS ACCEPTABLE.
4. MOUNT 4' RISER PIPE TO THE WALL USING SHOWN CONDUIT CLAMPS.
5. JOIN RISER PIPE TO ONT AT SHOWN LOCATION & MOUNT ONT TO THE WALL.
6. PLACE FIBER FROM DUCT INTO RISER PIPE AND INTO ONT.
7. LEAVE 5' OF SLACK INSIDE OF THE ONT. SLACK SHOULD BE LOOSELY STORED AND NOT LOOPED TIGHTLY.

**General Notes**



NOTIFY ALL UTILITIES 72 HOURS PRIOR TO CONSTRUCTION ACTIVITY. ONE CALL SYSTEM @ 1-800-227-6477

No.	Revision/Issue	Date

DISCLAIMER: EXCEPT AS MAY BE OTHERWISE PROVIDED BY CONTRACT, THESE DRAWINGS AND SPECIFICATIONS SHALL REMAIN THE PROPERTY OF TELEPAK NETWORKS INC. BEING ISSUED IN STRICT CONFIDENCE AND SHALL NOT BE REPRODUCED, COPIED, OR USED FOR ANY PURPOSE WITHOUT SPECIFIC WRITTEN PERMISSION.

Prepared By



Prepared For

Project Details

Date 4/14/2026

Map Number

Scale

T-6

Sheet 7 of 17

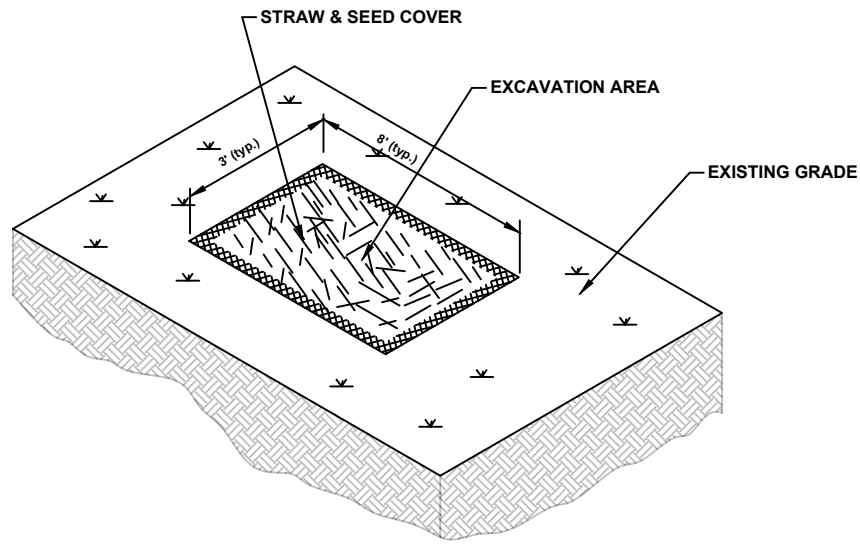

TYPICAL EROSION DETAIL #1  
NOTE TO CONSTRUCTION:

WHERE APPLICABLE  
RE-COMPACT SOIL AROUND  
HANDHOLES AND BOREPITS  
USE HAY AND SEED COVER  
FOR EROSION CONTROL.

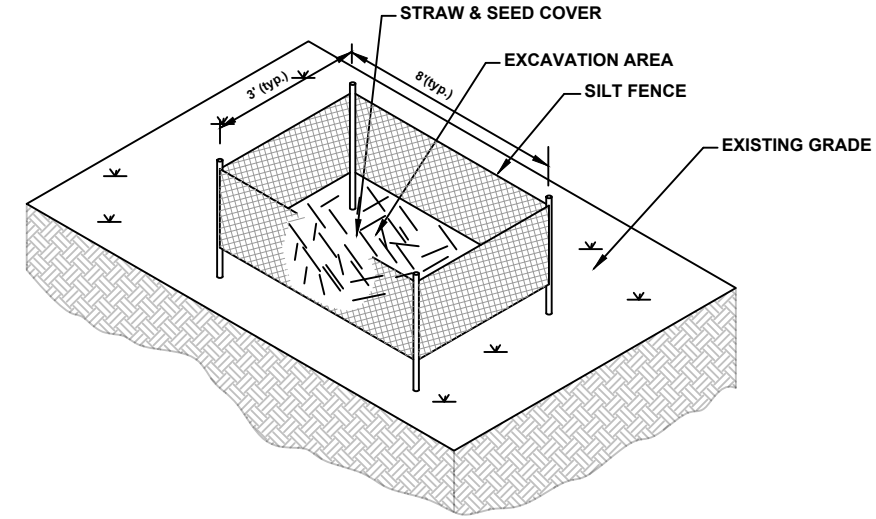

TYPICAL EROSION DETAIL #2  
NOTE TO CONSTRUCTION:

FOR HIGHER DEGREE OF SLOPE  
RE-COMPACT SOIL AROUND  
HANDHOLES AND BOREPITS. USE  
HAY, SEED AND SILT FENCES FOR  
EROSION CONTROL.

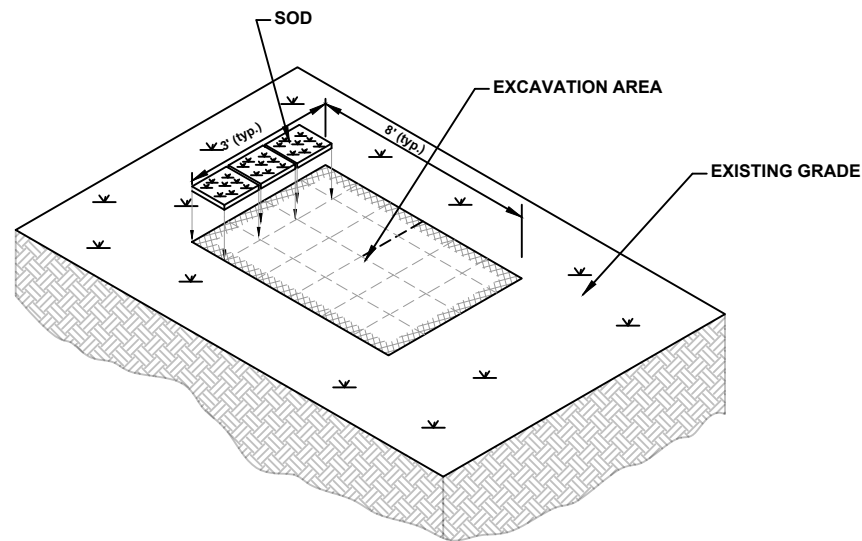

TYPICAL EROSION DETAIL #3  
NOTE TO CONSTRUCTION:

FOR EROSION CONTROL IN  
WELL MANICURED AREAS  
RE-COMPACT SOIL AROUND  
HANDHOLES AND  
BOREPITS. RE-SOD TO  
MATCH EXISTING GROUND  
COVER.

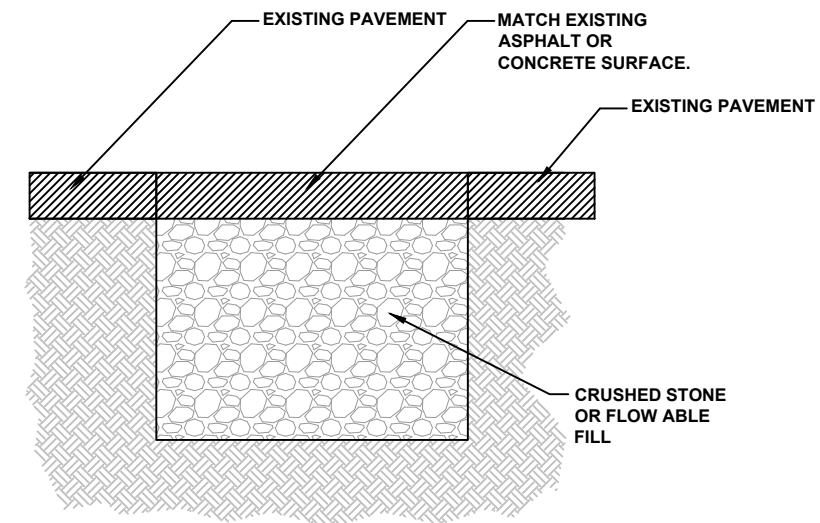

TYPICAL PAVEMENT REPAIR

DETAIL #4  
NOTE TO CONSTRUCTION:

RE-COMPACT EFFECTED  
AREAS WITH CRUSHED  
STONE OR FLOWABLE FILL.  
MATCH EXISTING PAVEMENT  
SURFACE.

General Notes



NOTIFY ALL UTILITIES 72 HOURS  
PRIOR  
TO CONSTRUCTION ACTIVITY.  
ONE CALL SYSTEM @  
1-800-227-6477

No.	Revision/Issue	Date

DISCLAIMER:  
EXCEPT AS MAY BE OTHERWISE PROVIDED BY  
CONTRACT, THESE DRAWINGS AND SPECIFICATIONS  
SHALL REMAIN THE PROPERTY OF TELEPAK  
NETWORKS INC. BEING ISSUED IN STRICT  
CONFIDENCE AND SHALL NOT BE REPRODUCED,  
COPIED, OR USED FOR ANY PURPOSE  
WITHOUT SPECIFIC WRITTEN PERMISSION.

Prepared By



Prepared For

Project Details

Date 4/14/2026

Scale

Map Number

T-7

Sheet 8 of 17

## DIELECTRIC TEST STATION (DTS) TYPICALS

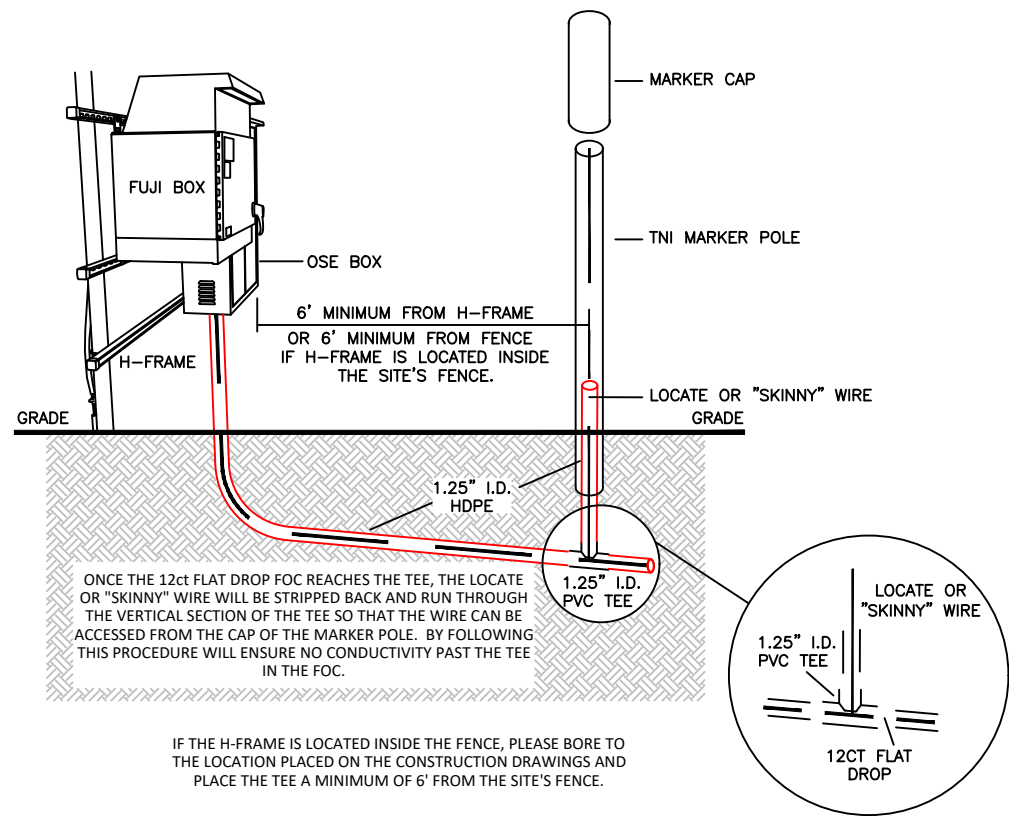

## FLUSH MOUNTED WATER BOX INSTALLATION OPTION TWO

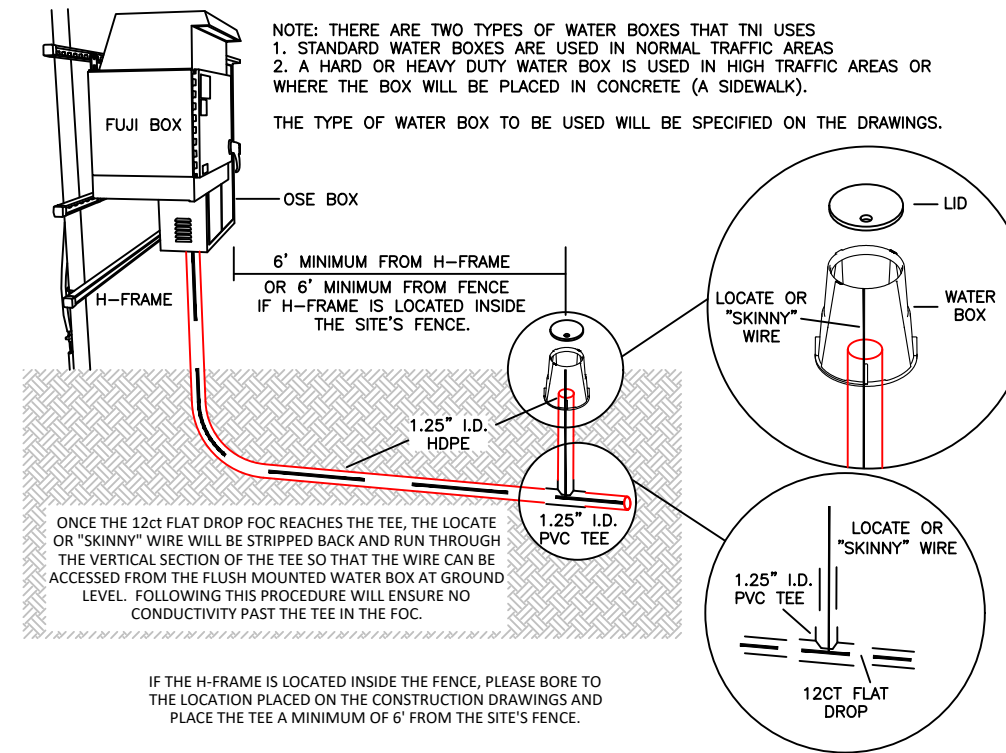

## THREADED PVC FLUSH MOUNTED ACCESS CAP OPTION THREE

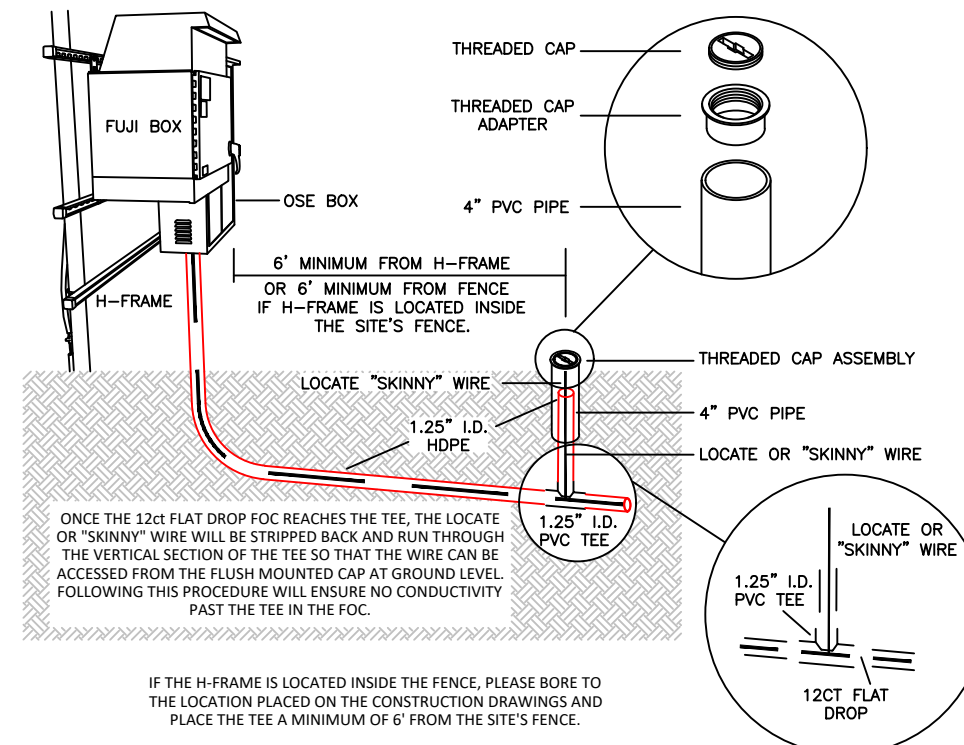

### General Notes



NOTIFY ALL UTILITIES 72 HOURS PRIOR TO CONSTRUCTION ACTIVITY. ONE CALL SYSTEM @ 1-800-227-6477

No.	Revision/Issue	Date

DISCLAIMER: EXCEPT AS MAY BE OTHERWISE PROVIDED BY CONTRACT, THESE DRAWINGS AND SPECIFICATIONS SHALL REMAIN THE PROPERTY OF TELEPAK NETWORKS INC. BEING ISSUED IN STRICT CONFIDENCE AND SHALL NOT BE REPRODUCED, COPIED, OR USED FOR ANY PURPOSE WITHOUT SPECIFIC WRITTEN PERMISSION.

Prepared By



Prepared For

Project Details

Date 4/14/2026

Scale

Sheet 9 of 17

Map Number

T-8



# SIDEWALK CUT & RESTORE TYPICAL DETAIL

SIDEWALK MUST BE ADA COMPLIANT WHERE APPLICABLE

**TYPICAL DETAIL "A"**  
CONCRETE CUT & RESTORE  
REPLACEMENT

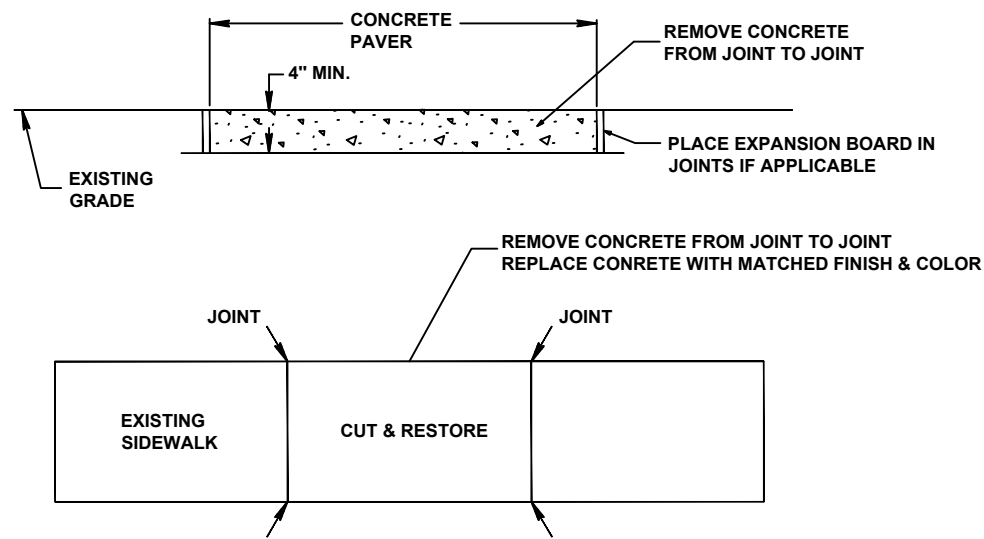

**TYPICAL DETAIL "B"**  
HANDHOLE INSTALLATION IN  
CONCRETE SIDEWALK

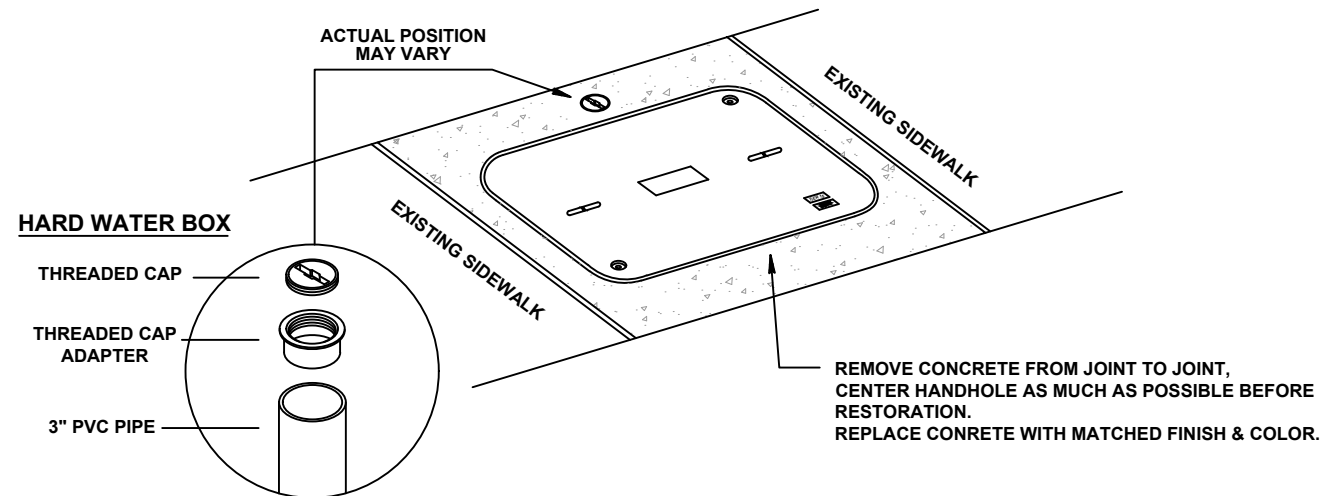
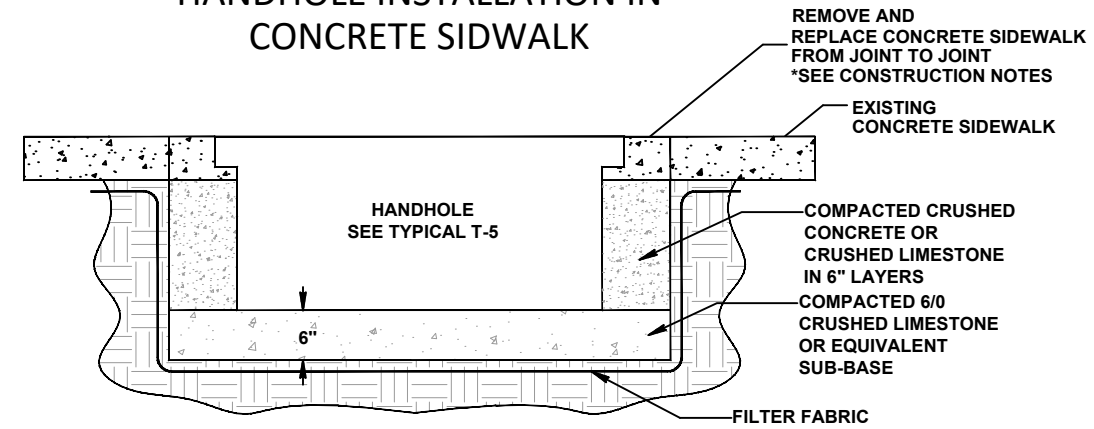

**AT EVERY HANDHOLE LOCATION  
WITH TEST WIRE IN A SIDEWALK,  
IF APPLICABLE, INSTALL A FLUSH  
MOUNT HARD WATER BOX.  
RESTORE CONCRETE TO ORIGINAL  
FINISH & COLOR**

**CONSTRUCTION NOTES:**

1. PROVIDE BARRIERS AND TRAFFIC CONTROL PER MUTCD REV.3 OR NEWER.
2. CUT & RESTORE AREAS SHALL BE RETURNED TO ORIGINAL, OR BETTER CONDITION.
3. SIDEWALKS THAT HAVE EXPANSION BOARD IN USE IN ADJACENT AREAS SHALL BE RESTORED WITH EXPANSION BOARD.
4. EXPOSED AGGREGATE FINISHED SIDEWALKS SHALL BE RESTORED WITH SAME FINISH.
5. ENSURE FINISH IS SLIP RESISTANT.
6. BRICK SIDEWALKS SHALL BE RESTORED TO THE SAME FINISH.
7. ENSURE FLUSH MOUNT TEST STATIONS DO NOT PRESENT A TRIP HAZARD.
8. COVER CONCRETE FOR A MINIMUM OF 12 HOURS PRIOR TO REMOVING PEDESTRIAN BARRIERS.
9. RESTORATION AREA MUST BE RESTORED TO AN OPERATIONAL SIDEWALK PRIOR TO CLOSING ANY CONSTRUCTION PERMITS.

**General Notes**



NOTIFY ALL UTILITIES 72 HOURS PRIOR TO CONSTRUCTION ACTIVITY. ONE CALL SYSTEM @ 1-800-227-6477

No.	Revision/Issue	Date

DISCLAIMER:  
EXCEPT AS MAY BE OTHERWISE PROVIDED BY CONTRACT, THESE DRAWINGS AND SPECIFICATIONS SHALL REMAIN THE PROPERTY OF TELEPAK NETWORKS INC. BEING ISSUED IN STRICT CONFIDENCE AND SHALL NOT BE REPRODUCED, COPIED, OR USED FOR ANY PURPOSE WITHOUT SPECIFIC WRITTEN PERMISSION.

Prepared By



Prepared For

Project Details

Date 4/14/2026

Map Number

Scale

T-9

Sheet 10 of 17

# TRACE-SAFE Termination Test Station

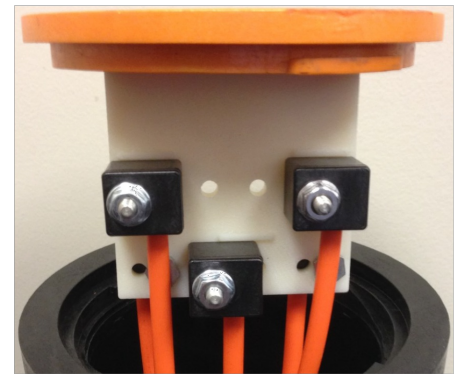
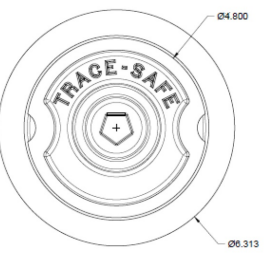
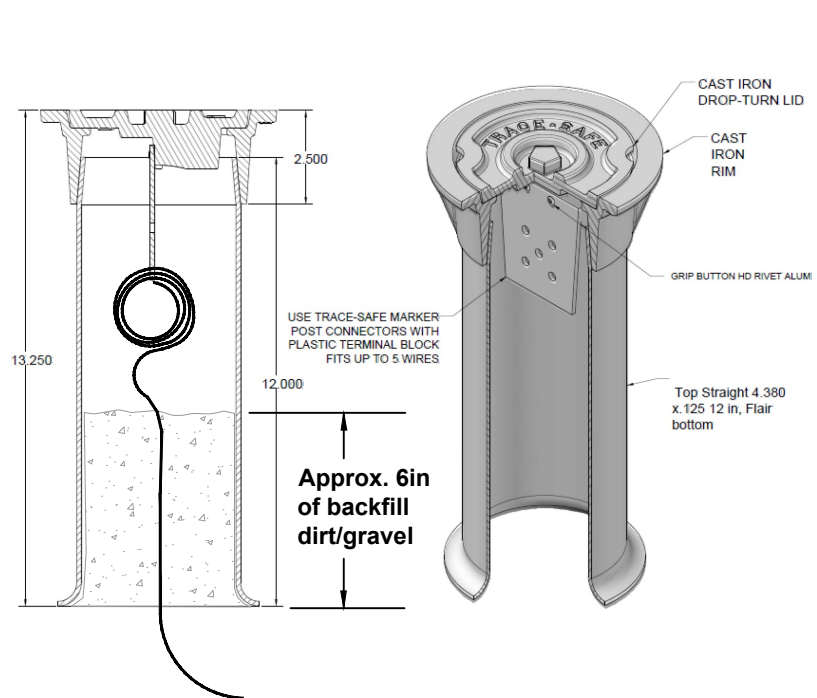
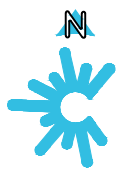

12in Tail for testing

**Grounding Trace-Safe inside test station**

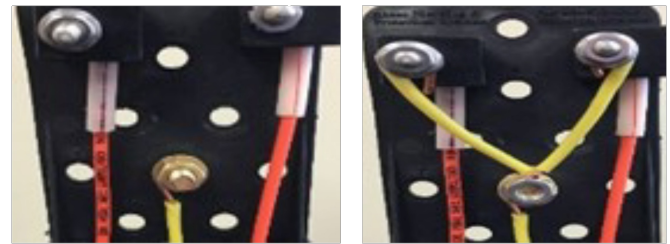

Install TRACE-SAFE and ground wire using TS-MPC no-strip connectors

Pigtail jumper wire between TRACE-SAFE and ground wire stud

**To locate:**  
Disconnect pigtail from TRACE-SAFE stud to isolate the line you would like to locate. Replace the pigtail when job is completed.

**NOTES:**

1. THIS ASSEMBLY IS RATED FOR A STATIC DESIGN LOAD OF 15,000 LBS. [66,720 N] OVER A 10 [254] X 10 [254] AREA AND MUST PASS A MIN. STATIC TEST LOAD OF 22,500 LBS. [100,085 N].
2. ALL ENCLOSURES, BOXES AND COVERS, ARE REQUIRED TO CONFORM TO ALL TEST PROVISIONS OF ANSI/SCTE 77 2007 "SPECIFICATION FOR UNDERGROUND ENCLOSURE INTEGRITY" AS MANUFACTURED BY QUAZITE OR EQUIVALENT WITH TELEPAK NETWORK'S ENGINEER'S SIGNED APPROVAL. THE COVERS MUST BE RATED FOR TIER 15 APPLICATIONS AND BOXES RATED FOR TIER 22 APPLICATIONS AND IN NO ASSEMBLY CAN THE COVER DESIGN LOAD EXCEED THE DESIGN LOAD OF THE BOX. ALL COMPONENTS IN AN ASSEMBLY (BOX & COVER) ARE MANUFACTURED USING MATCHED SURFACE TOOLING. ALL COVERS ARE REQUIRED TO HAVE A MINIMUM COEFFICIENT OF FRICTION OF 0.50 IN ACCORDANCE WITH ASTM C 1028 AND HAVE TIER 15 AND "TELEPAK NETWORKS 800-342-3716" EMBOSSED ON THE TOP SURFACE. ALL COVER BOLTS TO BE SELF-CLEANING AUGER BOLT ASSEMBLIES.

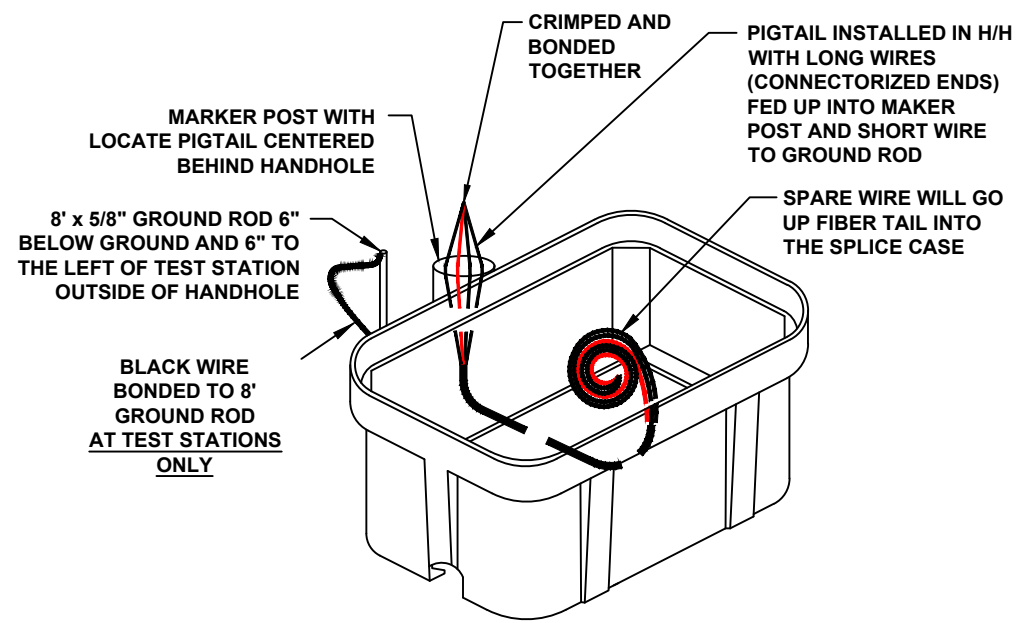

**SIDE PROFILE**

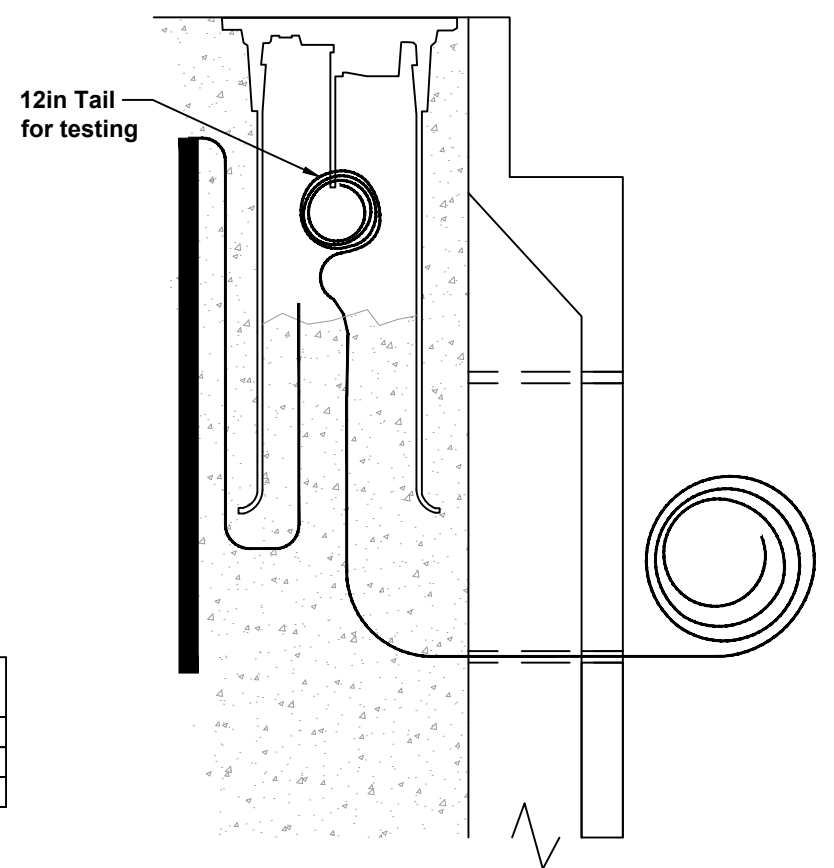

PIGTAILS ARE TO BE INSTALLED AT TEST STATION (T.S.) ONLY.  
HANDHOLES ARE TO BE INSTALLED A MINIMUM OF THREE FEET FROM ANY UTILITY OR POWER POLE.

**BOXES (Nestable)**

DESCRIPTION	PART NO.	WEIGHT	DESIGN/TEST LOAD#
UH-5 30x60x36	PG3060Z501	933# 423KG.	15'000 LBS
UH-4 30x48x36	PG3048Z579	563# 255KG.	15'000 LBS
UH-3 24x36x24	PG2436Z905	284# 129KG.	15'000 LBS

DIMENSIONS ARE IN INCHES OR MILLIMETERS IN BRACKETS UNLESS OTHERWISE NOTED.

**General Notes**  
811 NOTIFY ALL UTILITIES 72 HOURS PRIOR TO CONSTRUCTION ACTIVITY. ONE CALL SYSTEM @ 1-800-227-6477

No.	Revision/Issue	Date

DISCLAIMER:  
EXCEPT AS MAY BE OTHERWISE PROVIDED BY CONTRACT, THESE DRAWINGS AND SPECIFICATIONS SHALL REMAIN THE PROPERTY OF TELEPAK NETWORKS INC. BEING ISSUED IN STRICT CONFIDENCE AND SHALL NOT BE REPRODUCED, COPIED, OR USED FOR ANY PURPOSE WITHOUT SPECIFIC WRITTEN PERMISSION.

Prepared By

Prepared For

Project Details

Date: 4/14/2026  
Scale:  
Sheet 11 of 17  
Map Number: T-10

# TRACE-SAFE Termination Test Station



# ASBUILT INSTALLATION

3IN 3/4 IN CARRIAGE BOLT WITH NYLON NUT  
4IN MINRLAC CONDUIT HANGER



**General Notes**

**811** NOTIFY ALL UTILITIES 72 HOURS PRIOR TO CONSTRUCTION ACTIVITY. ONE CALL SYSTEM @ 1-800-227-6477

No.	Revision/Issue	Date

DISCLAIMER:  
EXCEPT AS MAY BE OTHERWISE PROVIDED BY CONTRACT, THESE DRAWINGS AND SPECIFICATIONS SHALL REMAIN THE PROPERTY OF TELEPAK NETWORKS INC. BEING ISSUED IN STRICT CONFIDENCE AND SHALL NOT BE REPRODUCED, COPIED, OR USED FOR ANY PURPOSE WITHOUT SPECIFIC WRITTEN PERMISSION.

Prepared By

Prepared For

Project Details

Date	4/14/2026	Map Number	T-11
Scale			
Sheet	12 of 17		

# STANDARDS FOR ALL DESIGN METHODS



The duct entering any vault must enter at a 45-degree angle and be 4-6 inches above the dirt/gravel at the bottom of vault. When a UH-2 (11" x 18" x 18") up to a UH-3 (24" x 36" x 24") is needed, a 1-inch bed of gravel (#57 stone) must be placed. Where a UH-4 vault (30" x 48" x 36") or UH-5 vault (30" x 60" x 36") is needed, it is required that a 4-inch bed of gravel (#57 stone) must be placed.

When using micro ducts, be sure to have a call out on the construction prints of what color duct to be used and what will remain underground (express) throughout the project. When using 18/14 2-way micro duct, the fiber will go in the blue duct and the orange duct will be used for drops.

Standard deployments using Quad: Blue - Distribution / Orange - Spare Distribution / Green - Metro\_Backbone / Brown - Spare Metro\_Backbone

Long haul projects with little to no distribution: Blue - Distribution / Orange - Metro\_Backbone / Green - Spare Metro\_Backbone / Brown - Spare Metro\_Backbone

(See typical below for details)

Tracer wires are not to be cut at pass-through handholes. Leave ground intact and in the ground. If it is broken, then it needs to be bonded. See typical drawings for connections of tracer wires for each duct type.

**BLUE** duct = 1    **ORANGE** duct = 2    **GREEN** duct = 3    **BROWN** duct = 4  
(Any additional pipe placed in the project well equal higher numbers)

## NOTES:

When deploying 144ct fiber, if Tyco D case is used, a UH-4 needs to be placed. If Tyco B case, a UH-3 needs to be placed.

Ground rods need to be shown at splice locations, PON cabinets and end of laterals.

All duct sizes and materials used should be called out on all documents associated with the project.

When pulling through any existing duct, it should be noted on the construction drawing.

All pipe installation should be at a minimum depth of 36" along the roadway and a minimum depth of 48" under the roadway.

For every handhole or pedestal that will house a splice, a minimum of 60' storage loop is required. For every handhole or pedestal that will not house a splice and it just for storage purposes, a minimum of 100' storage loop is required.

Two (2) drops can be placed in 1" pipe. Only one (1) drop per 18/14 micro duct.

For 1" tonable duct, 36" of the tracer wire will need to be placed in a water box (sprinkler box - 6" x 9") at splice locations, laterals, and the beginning and ending of fiber ends.

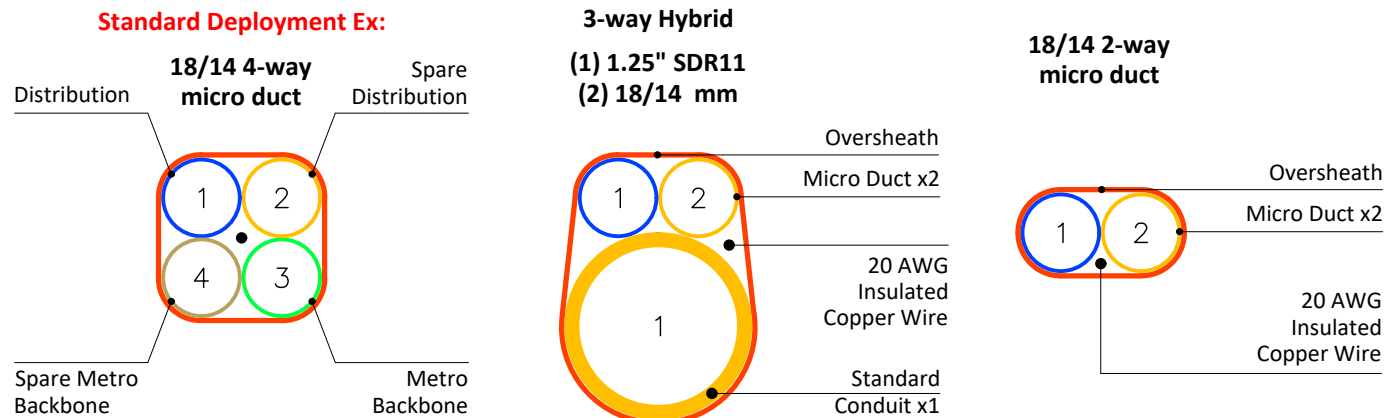

### Example UH-3 Pass Thru

Install a ground rod at any vault with a splice case

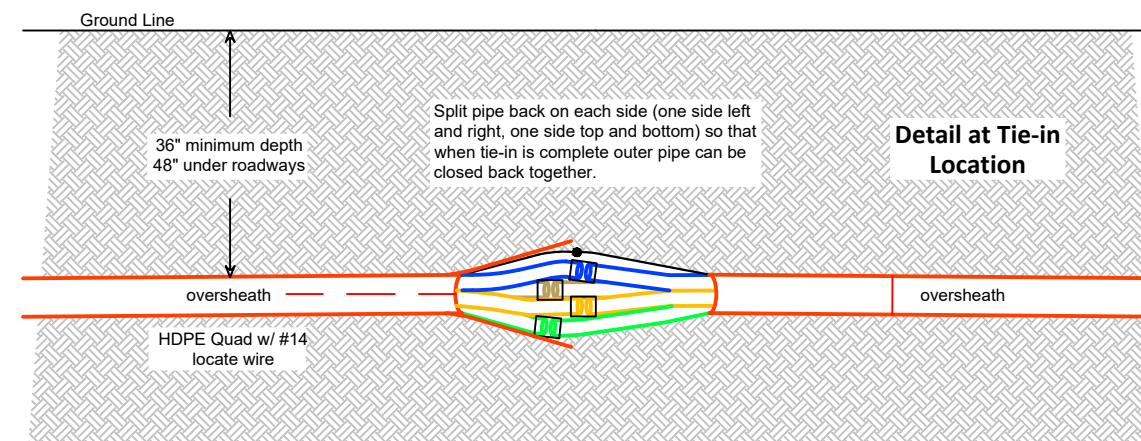
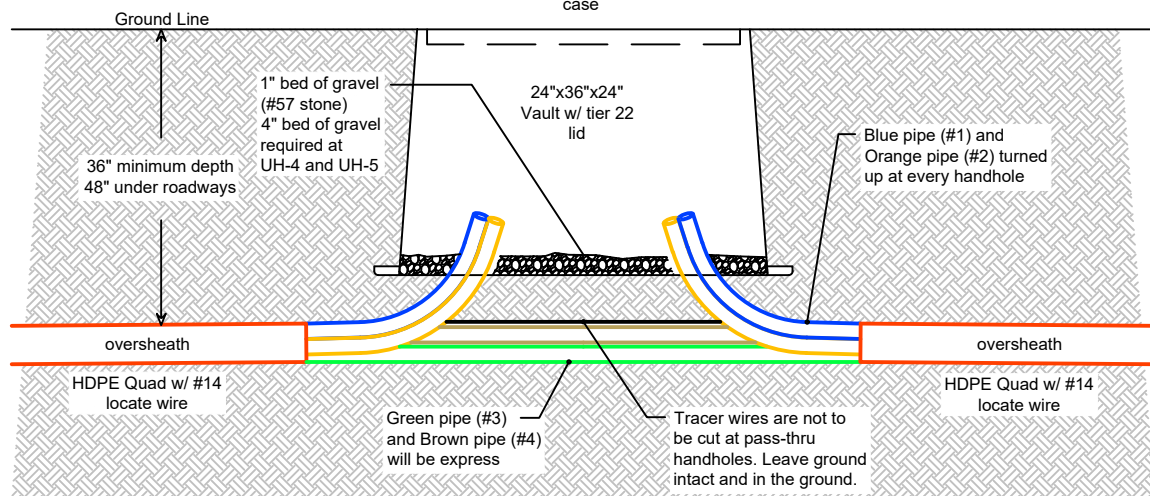
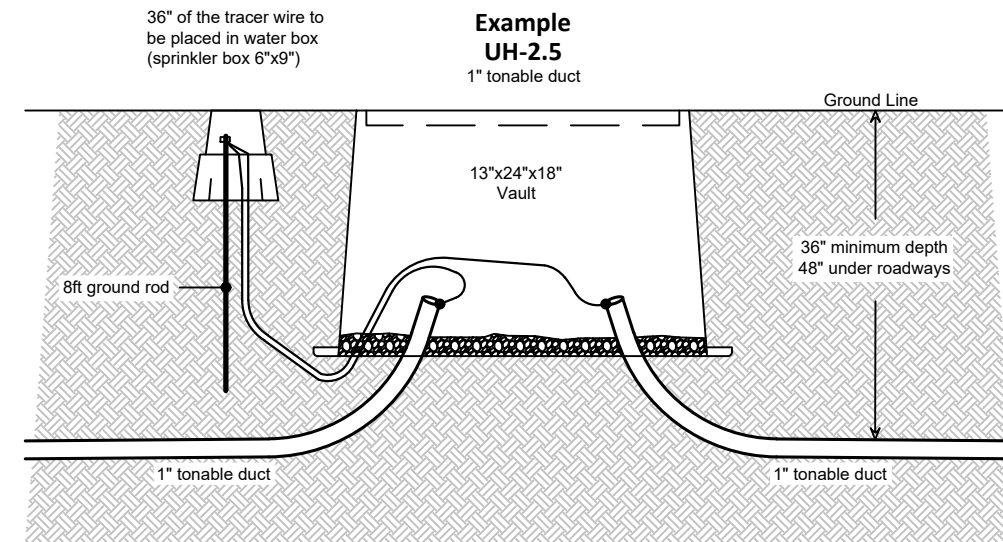

General Notes		
NOTIFY ALL UTILITIES 72 HOURS PRIOR TO CONSTRUCTION ACTIVITY. ONE CALL SYSTEM @ 1-800-227-6477		
No.	Revision/Issue	Date
DISCLAIMER: EXCEPT AS MAY BE OTHERWISE PROVIDED BY CONTRACT, THESE DRAWINGS AND SPECIFICATIONS SHALL REMAIN THE PROPERTY OF TELEPAK NETWORKS INC. BEING ISSUED IN STRICT CONFIDENCE AND SHALL NOT BE REPRODUCED, COPIED, OR USED FOR ANY PURPOSE WITHOUT SPECIFIC WRITTEN PERMISSION.		



Prepared For

Project Details

Date: 4/14/2026  
Scale:   
Sheet 13 of 17  
Map Number: T-12



# MICRO DISTRIBUTED TAP



**Description:** Micro Distributed Tap deployment is a 12ct fiber placed in a 1" HDPE pipe or 18/14 micro duct (2-Way (Dual Duct) or 4-Way (Quad Duct)) with a CSC100, Charles Yellowjacket or FOSS enclosure spliced and installed in a pedestal.

**Standards:** The pedestal is to be positioned with the front facing the road so the keyhole is located on the side and shall be buried up to the ground line indicated on the pedestal.

The duct that is entering the pedestal shall be 4 to 6 inches above the dirt inside of the pedestal. The ducts that are assigned to be expressed through the project will only be turned up at necessary intersections or where splice cases are required. When using micro duct, if a spare duct is turned up inside of the pedestal, it must be capped off using the micro duct end caps. We need to have clear instructions of what is happening at each pedestal.

Any time a FOSS enclosure is used, it will require a UH-3 (24" x 36" x 24").

A dummy tap will be needed at locations where the fiber is cut, including tails.

Tie-ins are to be done following the typical example and must be done correctly to ensure that the tracer wire is connected back together for locating.

## PED INSTALLATION DETAIL

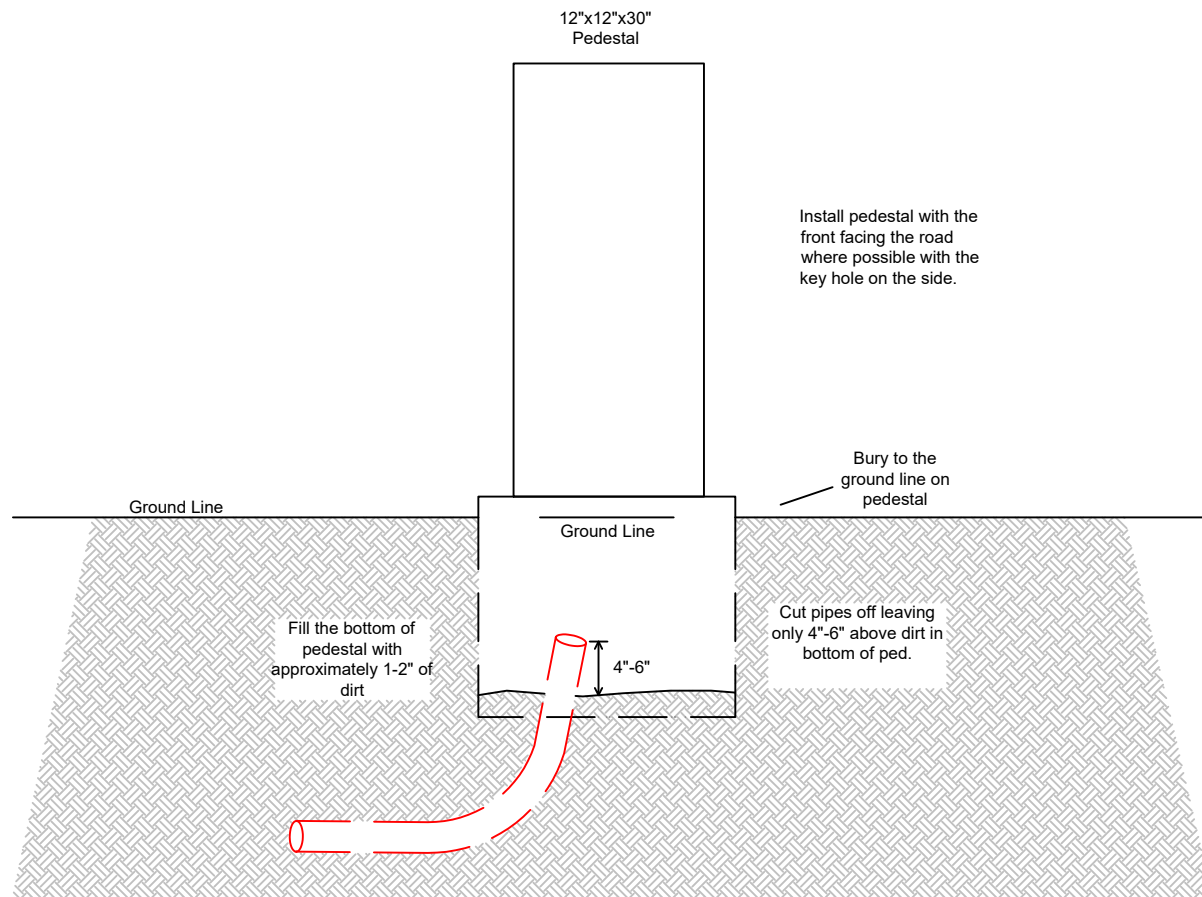

## PED DETAIL WITH TIE-IN'S WITH #14 WIRE

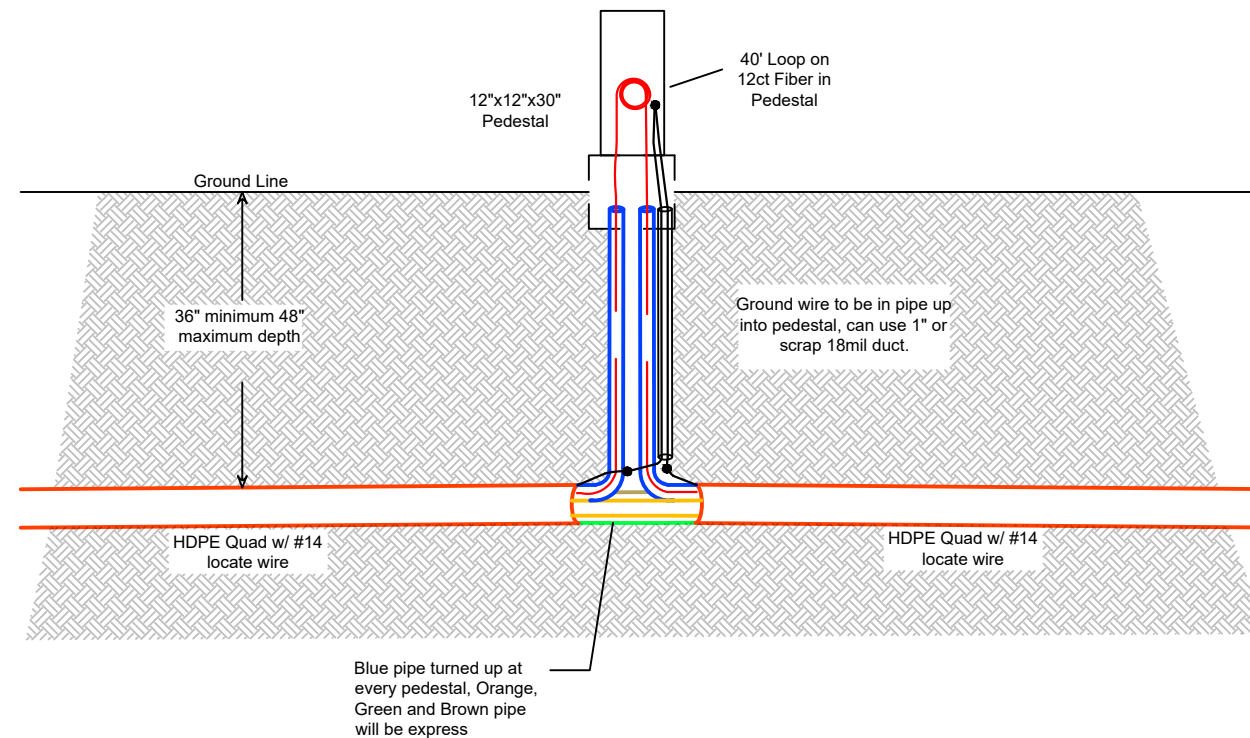

### General Notes



NOTIFY ALL UTILITIES 72 HOURS PRIOR TO CONSTRUCTION ACTIVITY. ONE CALL SYSTEM @ 1-800-227-6477

No.	Revision/Issue	Date

DISCLAIMER:  
EXCEPT AS MAY BE OTHERWISE PROVIDED BY CONTRACT, THESE DRAWINGS AND SPECIFICATIONS SHALL REMAIN THE PROPERTY OF TELEPAK NETWORKS INC. BEING ISSUED IN STRICT CONFIDENCE AND SHALL NOT BE REPRODUCED, COPIED, OR USED FOR ANY PURPOSE WITHOUT SPECIFIC WRITTEN PERMISSION.

Prepared By



Prepared For

Project Details

Date 4/14/2026

Scale

Sheet 14 of 17

Map Number

T-13



# MICRO CENTRALIZED SPLIT

Example: UH-2.5

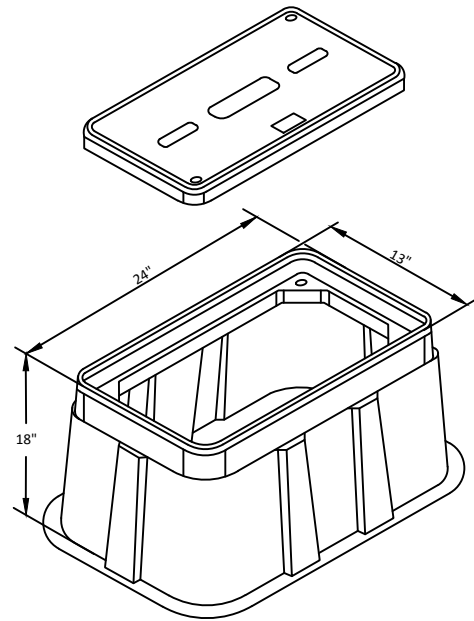

**Description:** Micro-Centralized Split deployment is a microfiber placed in a 1" HDPE pipe or 18/14 micro duct (2-Way (Dual Duct) or 4-Way (Quad Duct)) with a Mini OTE installed in UH-2.5 (13" x 24" x 18" equivalent) sized vault.

**Standards:** Microfiber installed in the 1" non-toneable HDPE duct must have a tracer wire and the microfiber installed in the 18/14 micro duct can be with or without tracer wire.

The Mini OTE will handle up to a 144ct microfiber spliced through and will allow an additional fiber (tail) to be spliced as needed. However, there is only room to make 12 splices inside of this enclosure. If more splices are required, then the vault size will need to be a UH-3 (24" x 36" x 24") minimum and will require the appropriately sized splice case.

When a Mini OTE is needed with a splice case in the same vault, it will require a 100' loop to be left inside of vault to splice the Mini OTE to the splice case.

All fiber needs to be utilized in splice trays from the cabinet.

With 18/14 micro duct 4-Way (Quad Duct) deployment, the Blue Duct (Duct 1) and Orange Duct (Duct 2) will be turned up in the UH-2.5 vaults (13" x 24" x 18") with the Green (Duct 3) and Brown (Duct 4) expressed unless otherwise noted. With 18/14 micro duct 2-Way (Dual Duct) deployment, the Blue Duct (Duct 1) and Orange Duct (Duct 2) will be turned up in the UH-2.5 vaults (13" x 24" x 18") and only the Orange Duct (Duct 2) turned up at every flowerpot (9.5" x 12" vault) unless otherwise noted. If a spare duct is turned up inside of the vault, it must be capped off using the micro duct end caps. The ducts that are assigned to be expressed through the project will only be turned up at necessary intersections or where splice cases are required. We need to have clear instructions of what is happening at each vault.

Tie-ins are to be done following the typical example and must be done correctly to ensure that the tracer wire is connected back together for locating.

Example: 12 port Mini-OTE 300

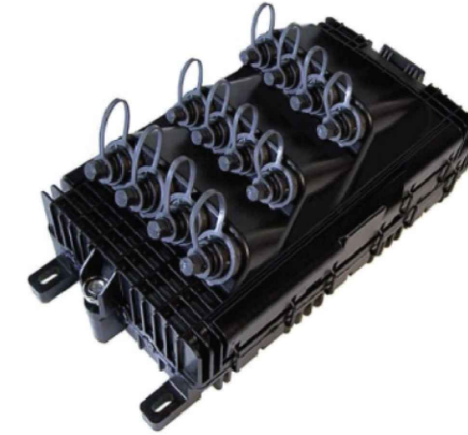

Example UH-3 Pass Thru

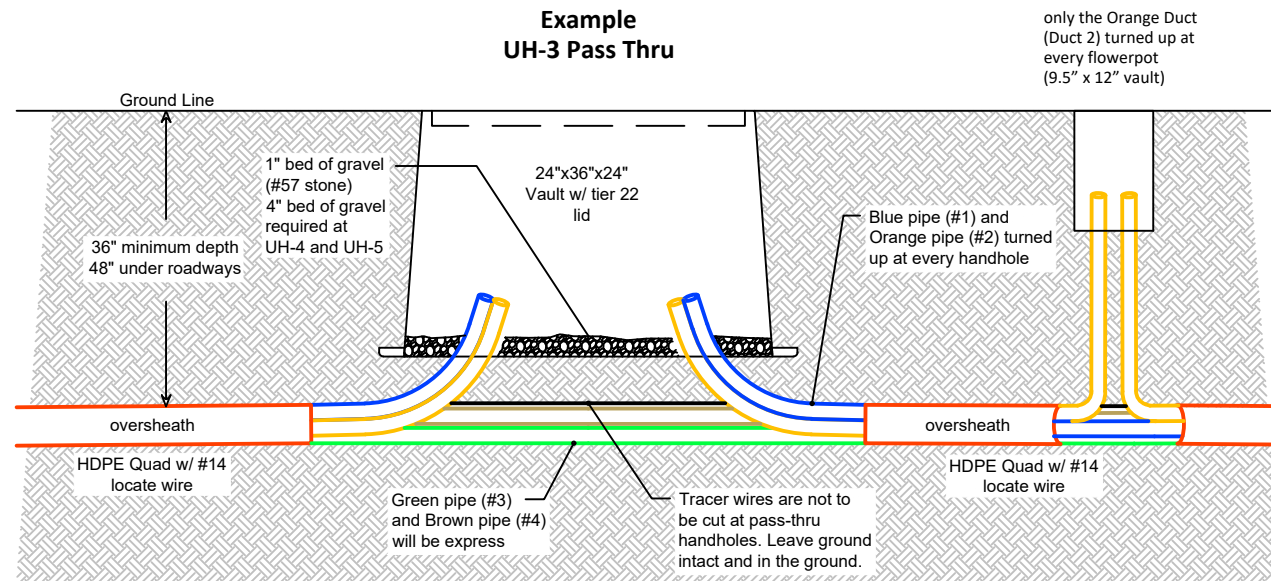

only the Orange Duct (Duct 2) turned up at every flowerpot (9.5" x 12" vault)

Example UH-3 Splice

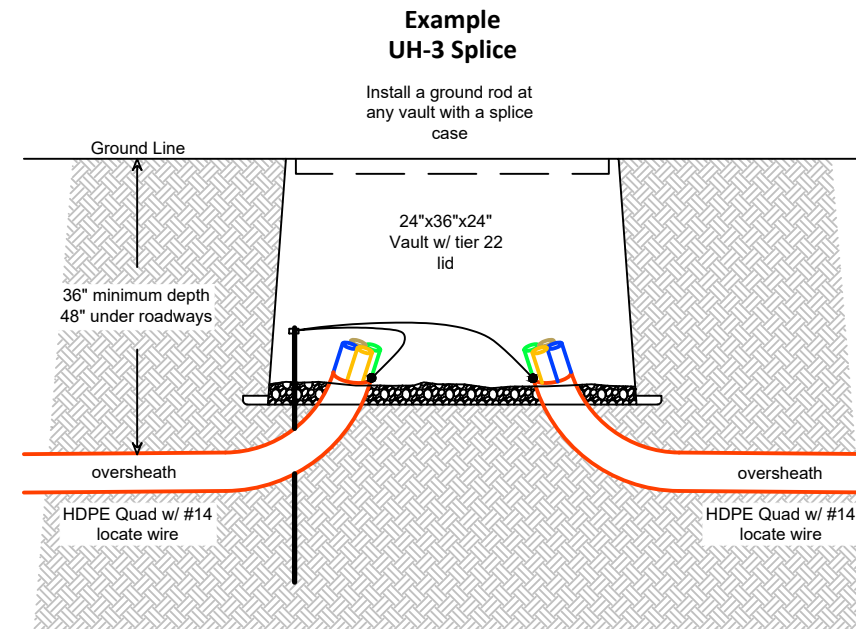

Install a ground rod at any vault with a splice case

General Notes

**811** NOTIFY ALL UTILITIES 72 HOURS PRIOR TO CONSTRUCTION ACTIVITY. ONE CALL SYSTEM @ 1-800-227-6477

No.	Revision/Issue	Date

DISCLAIMER: EXCEPT AS MAY BE OTHERWISE PROVIDED BY CONTRACT, THESE DRAWINGS AND SPECIFICATIONS SHALL REMAIN THE PROPERTY OF TELEPAK NETWORKS INC. BEING ISSUED IN STRICT CONFIDENCE AND SHALL NOT BE REPRODUCED, COPIED, OR USED FOR ANY PURPOSE WITHOUT SPECIFIC WRITTEN PERMISSION.

Prepared By



Prepared For

Project Details

Date	4/14/2026	Map Number	T-14
Scale			
Sheet 15 of 17			



# FULLY BELOW GRADE

Example: UH-2.5

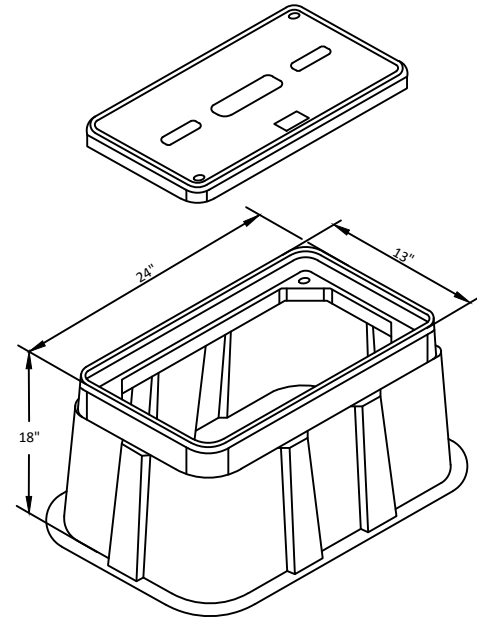

**Description:** Fully Below Grade deployment is a 12ct fiber placed in a 1" HDPE pipe or 18/14 micro duct (2-Way (Dual Duct) or 4-Way (Quad Duct)) with a CSC100, FOSC, or Mini OTE w/ splitter installed in a UH-2.5 (13" x 24" x 18" equivalent) sized vault.

**Standards:** With 18/14 micro duct 4-Way (Quad Duct) deployment, the Blue Duct (Duct 1) and Orange Duct (Duct 2) will be turned up in the UH-2.5 vaults (13" x 24" x 18") with the Green (Duct 3) and Brown (Duct 4) expressed unless otherwise noted. With 18/14 micro duct 2-Way (Dual Duct) deployment, the Blue Duct (Duct 1) and Orange Duct (Duct 2) will be turned up in the UH-2.5 vaults (13" x 24" x 18") and only the Orange Duct (Duct 2) turned up at every flowerpot (9.5" x 12" vault) unless otherwise noted. When 18/14 micro duct is used, the only time that all ducts will be turned up is when the drawing calls for a slack loop or a splice case. If a spare duct is turned up inside of the vault, it must be capped off using the micro duct end caps. The ducts that are assigned to be expressed through the project will only be turned up at necessary intersections or where splice cases are required. We need to have clear instructions of what is happening at each vault.

Any time a FOSC enclosure is used, it will require a UH-3 (24" x 36" x 24").

A dummy tap will be needed at locations where the fiber is cut, including tails.

Tie-ins are to be done following the typical example and must be done correctly to ensure that the tracer wire is connected back together for locating.

Example: CSC100 Compact Fiber Closure



Example UH-3 Pass Thru

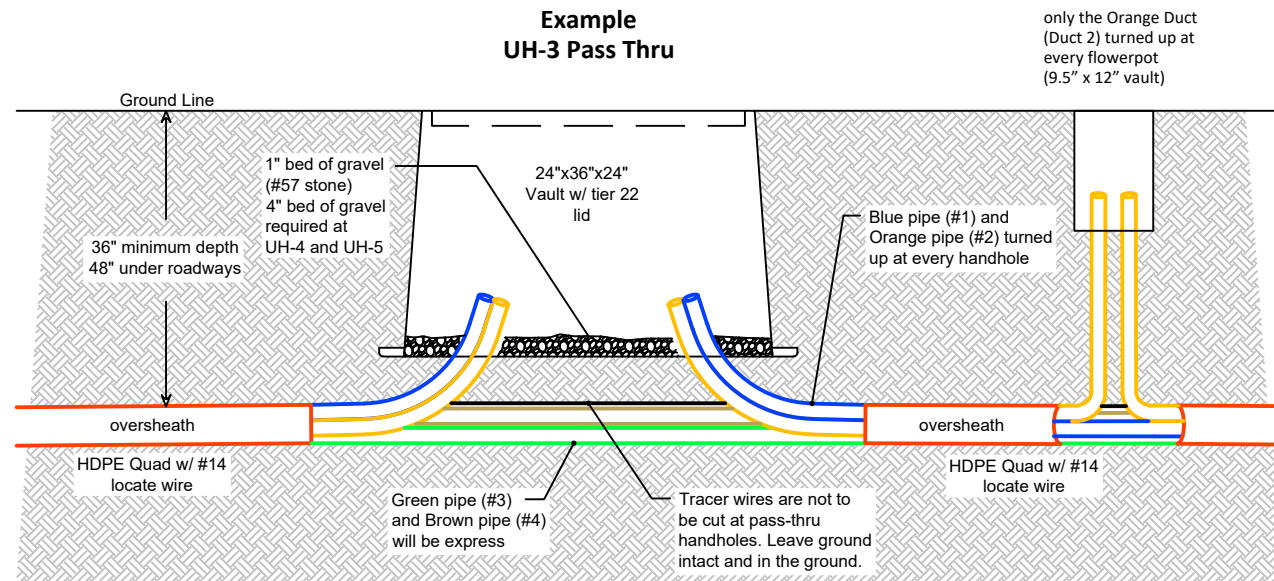

Example UH-3 Splice

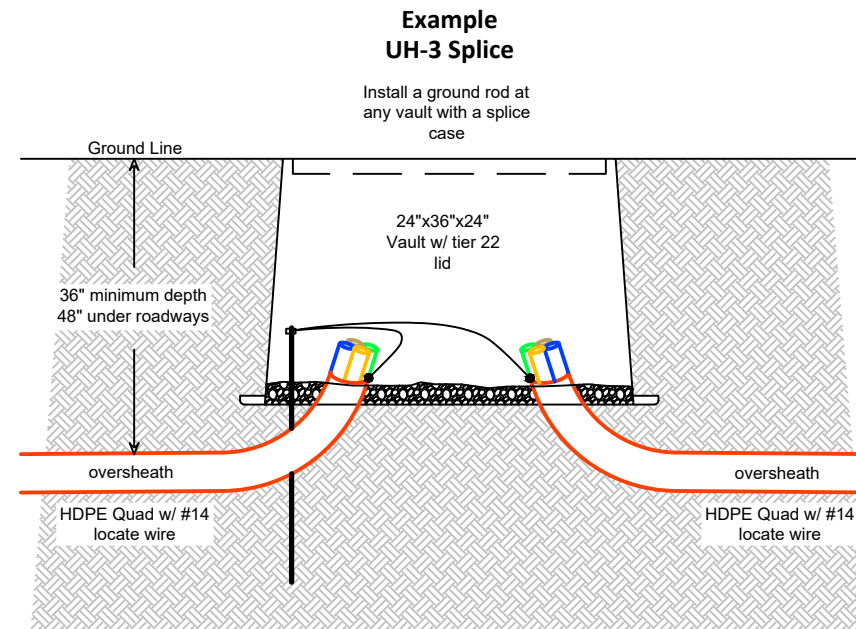

General Notes

**811** NOTIFY ALL UTILITIES 72 HOURS PRIOR TO CONSTRUCTION ACTIVITY. ONE CALL SYSTEM @ 1-800-227-6477

No.	Revision/Issue	Date

DISCLAIMER: EXCEPT AS MAY BE OTHERWISE PROVIDED BY CONTRACT, THESE DRAWINGS AND SPECIFICATIONS SHALL REMAIN THE PROPERTY OF TELEPAK NETWORKS INC. BEING ISSUED IN STRICT CONFIDENCE AND SHALL NOT BE REPRODUCED, COPIED, OR USED FOR ANY PURPOSE WITHOUT SPECIFIC WRITTEN PERMISSION.

Prepared By



Prepared For

Project Details

Date 4/14/2026

Scale

Sheet 16 of 17

Map Number

T-15



SEE SHEET 002

Existing build info see  
CLARK BEVERAGE-12043423

3+18 CABLE PI

2+65 POWER POLE 11'0/C  
2+58 HANDHOLE 2'0/C  
2+53 HANDHOLE 2'0/C

0+73 POWER POLE 17'0/C

CNTN11S3-W22  
(STA: 0+00)  
A) Existing UH-3 (24x36x24)  
A) PL. 8' GND ROD = 1  
A) 12CT FLAT FOC LOOP = 60'  
A) TYCO "B" SPLICE CASE = 1

0+00 EXIST. TNI HH

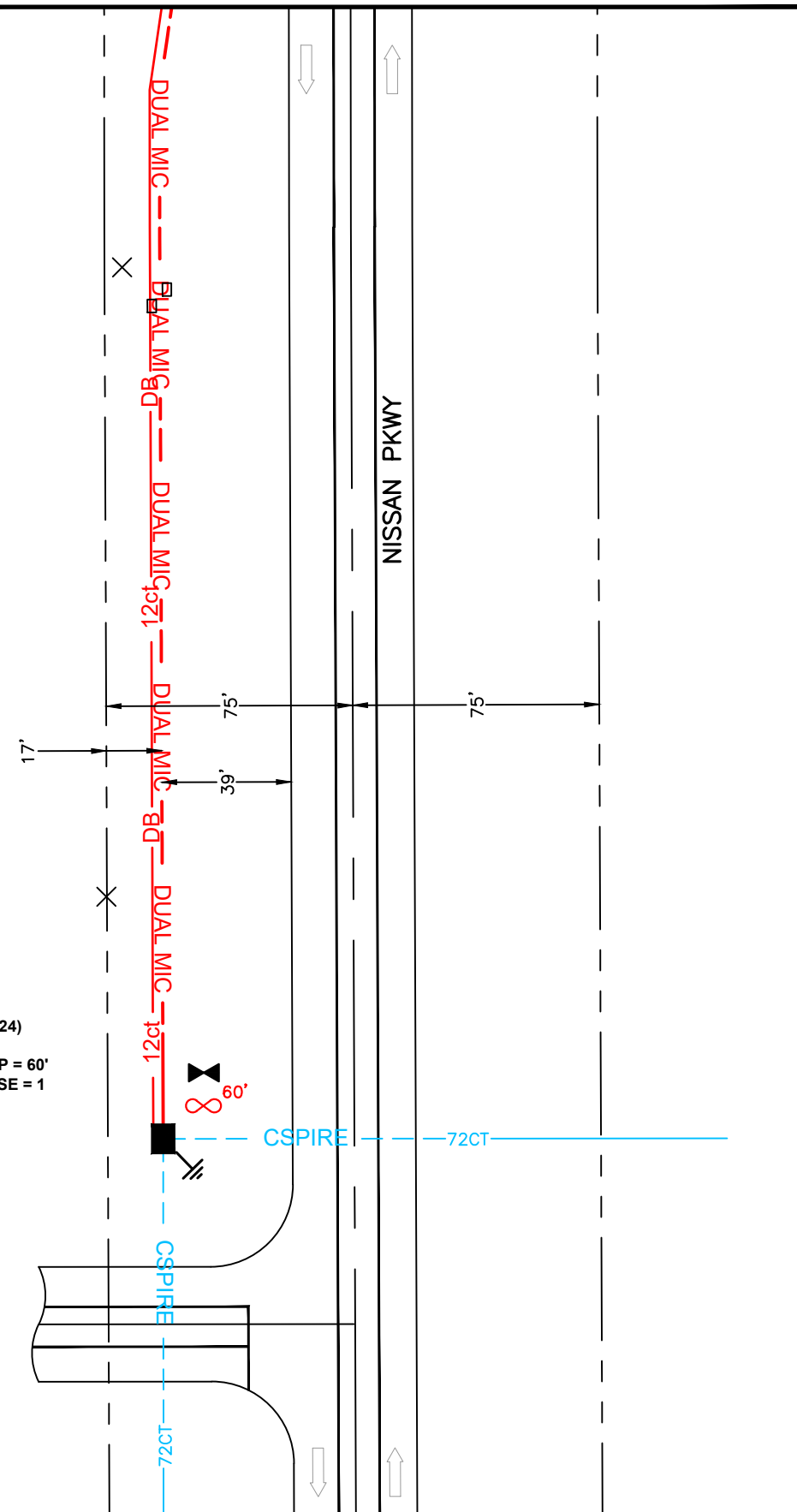

General Notes



NOTIFY ALL UTILITIES 72 HOURS  
PRIOR  
TO CONSTRUCTION ACTIVITY.  
ONE CALL SYSTEM @  
1-800-227-6477

No.	Revision/Issue	Date

DISCLAIMER:  
EXCEPT AS MAY BE OTHERWISE PROVIDED BY  
CONTRACT, THESE DRAWINGS AND SPECIFICATIONS  
SHALL REMAIN THE PROPERTY OF TELEPAK  
NETWORKS INC. BEING ISSUED IN STRICT  
CONFIDENCE AND SHALL NOT BE REPRODUCED,  
COPIED, OR USED FOR ANY PURPOSE  
WITHOUT SPECIFIC WRITTEN PERMISSION.

Prepared By



Prepared For

Project Details

STATE CONTRACT-MADISON  
COUNTY BOARD OF  
SUPERVISORS CANTON  
363 MADISON COUNTY PKWY, CANTON MS  
39046  
OSP Subproject 78070-001  
ACCOUNTING CODE 363865  
MADISON

Date 4/14/2026

Map Number

Scale 1:50

001

Sheet 17 of 17

SEE SHEET 003

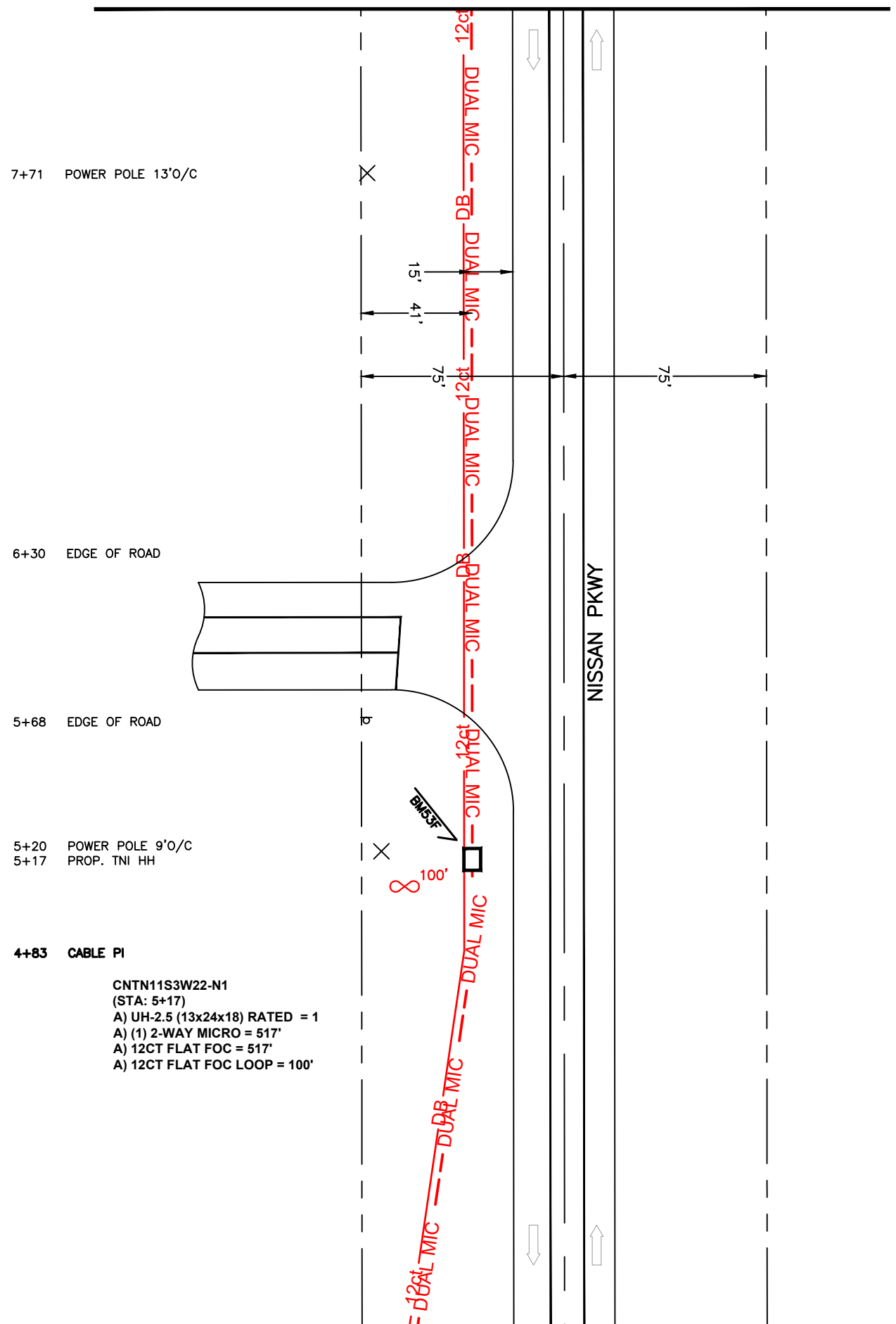

SEE SHEET 001



General Notes



NOTIFY ALL UTILITIES 72 HOURS PRIOR TO CONSTRUCTION ACTIVITY. ONE CALL SYSTEM @ 1-800-227-6477

No.	Revision/Issue	Date

DISCLAIMER: EXCEPT AS MAY BE OTHERWISE PROVIDED BY CONTRACT, THESE DRAWINGS AND SPECIFICATIONS SHALL REMAIN THE PROPERTY OF TELEPAK NETWORKS INC. BEING ISSUED IN STRICT CONFIDENCE AND SHALL NOT BE REPRODUCED, COPIED, OR USED FOR ANY PURPOSE WITHOUT SPECIFIC WRITTEN PERMISSION.

Prepared By



Prepared For

Project Details

STATE CONTRACT-MADISON COUNTY BOARD OF SUPERVISORS CANTON 363 MADISON COUNTY PKWY, CANTON MS 39046 OSP Subproject 78070-001 ACCOUNTING CODE 363865 MADISON

Date 4/14/2026

Map Number

Scale 1:50

002

Sheet 18 of 17

SEE SHEET 004

12+83 POWER POLE 3'0/C

12+68 EDGE OF ROAD

12+17 EDGE OF ROAD

CNTN11S3W22-N2  
 (STA: 10+50)  
 A) UH-2.5 (13x24x18) NON RATED = 1  
 A) (1) 2-WAY MICRO = 533'  
 A) 12CT FLAT FOC = 533'  
 A) 12CT FLAT FOC LOOP = 100'

10+56 100' 4'0/C  
 10+50 PROP. TNI HH

10+22 POWER POLE 5'0/C

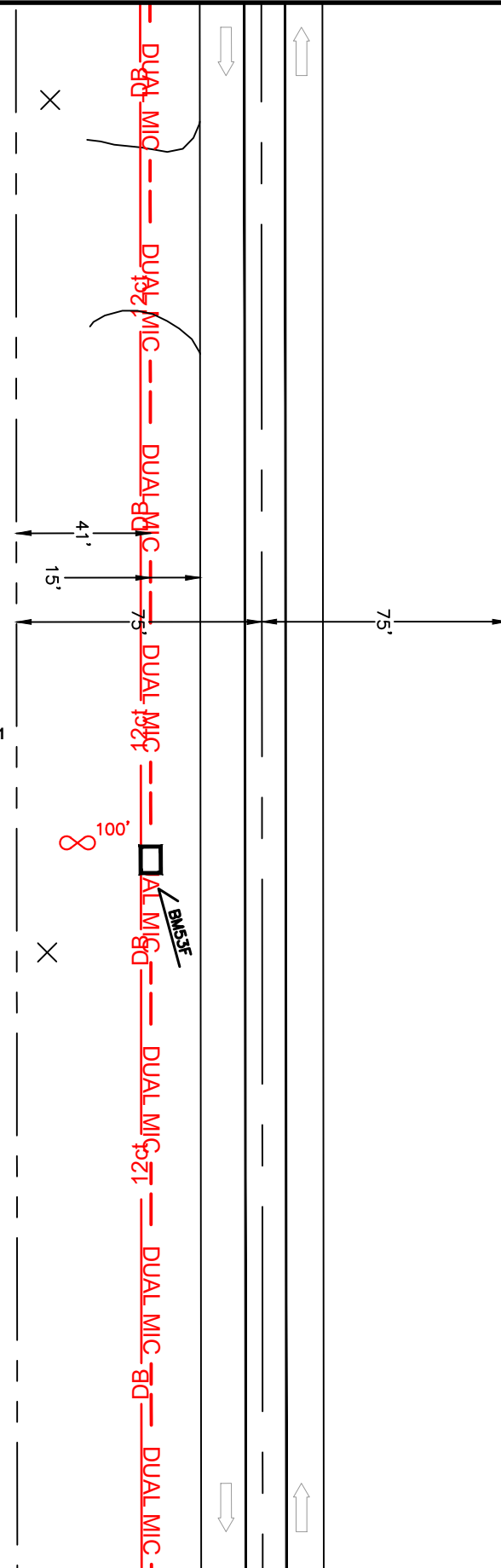

SEE SHEET 002



General Notes



NOTIFY ALL UTILITIES 72 HOURS PRIOR TO CONSTRUCTION ACTIVITY. ONE CALL SYSTEM @ 1-800-227-6477

No.	Revision/Issue	Date

DISCLAIMER:  
 EXCEPT AS MAY BE OTHERWISE PROVIDED BY CONTRACT, THESE DRAWINGS AND SPECIFICATIONS SHALL REMAIN THE PROPERTY OF TELEPAK NETWORKS INC. BEING ISSUED IN STRICT CONFIDENCE AND SHALL NOT BE REPRODUCED, COPIED, OR USED FOR ANY PURPOSE WITHOUT SPECIFIC WRITTEN PERMISSION.

Prepared By



Prepared For

Project Details

STATE CONTRACT-MADISON  
 COUNTY BOARD OF SUPERVISORS CANTON  
 363 MADISON COUNTY PKWY, CANTON MS 39046  
 OSP Subproject 78070-001  
 ACCOUNTING CODE 363865  
 MADISON

Date 4/14/2026

Scale 1:50

Map Number

003

Sheet 19 of 17





@22+66 C Spire will directional bore to the marked location flagged and white lined. CSpire will then dig down 6" and penetrate 4" conduit underground.

Madison County Board of Supervisors Canton  
 363 Madison County Pkwy, Canton M  
 Duane Thompson 601-855-5508

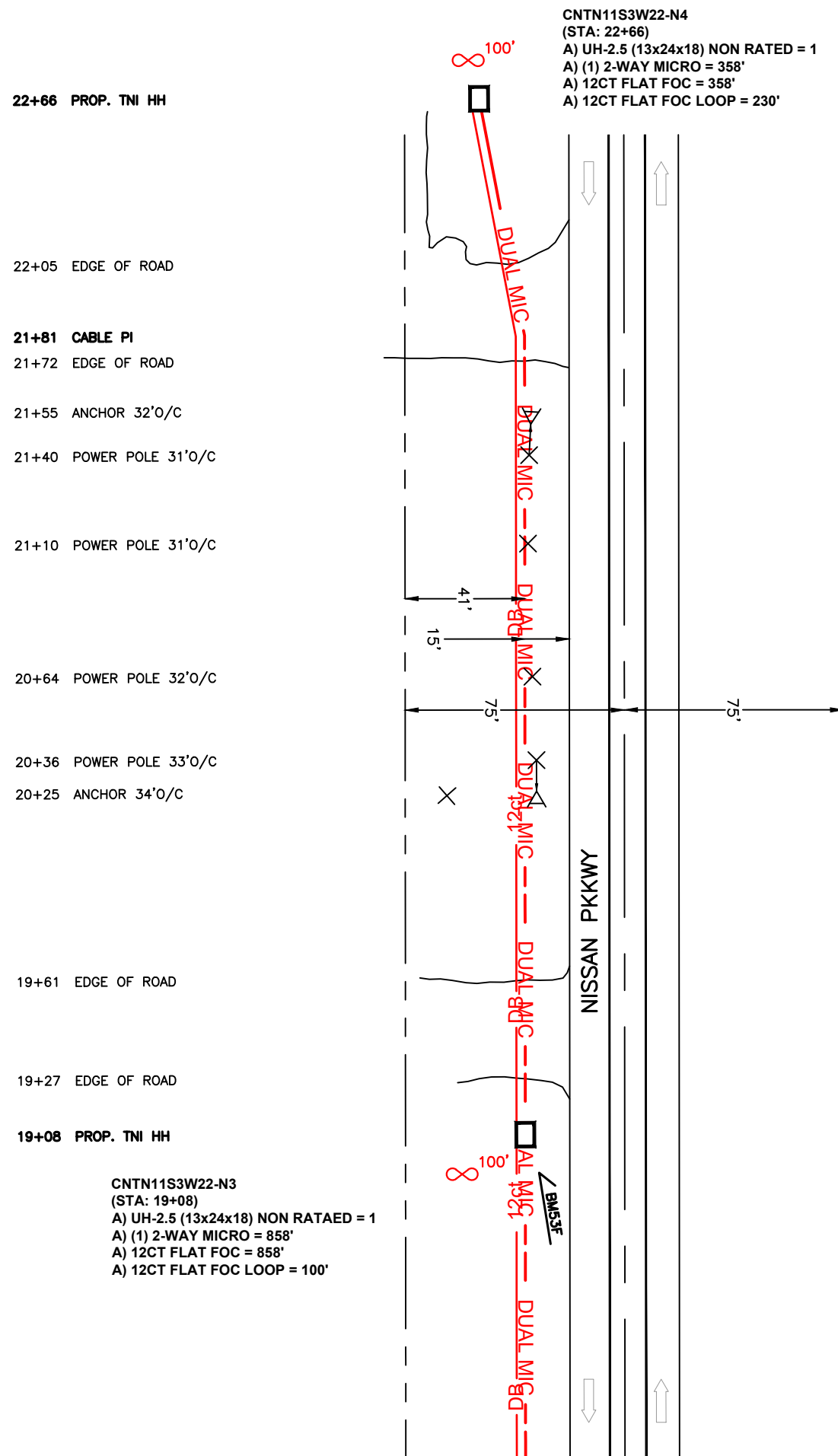

**General Notes**

**811** NOTIFY ALL UTILITIES 72 HOURS PRIOR TO CONSTRUCTION ACTIVITY. ONE CALL SYSTEM @ 1-800-227-6477

No.	Revision/Issue	Date

DISCLAIMER:  
 EXCEPT AS MAY BE OTHERWISE PROVIDED BY CONTRACT, THESE DRAWINGS AND SPECIFICATIONS SHALL REMAIN THE PROPERTY OF TELEPAK NETWORKS INC. BEING ISSUED IN STRICT CONFIDENCE AND SHALL NOT BE REPRODUCED, COPIED, OR USED FOR ANY PURPOSE WITHOUT SPECIFIC WRITTEN PERMISSION.

Prepared By

Prepared For

Project Details  
 STATE CONTRACT-MADISON COUNTY BOARD OF SUPERVISORS CANTON  
 363 MADISON COUNTY PKWY, CANTON MS 39046  
 OSP Subproject 78070-001  
 ACCOUNTING CODE 363865  
 MADISON

Date	4/14/2026	Map Number	005
Scale	1:50	Sheet 21 of 17	